

On December 10, 1973, I arrived in Birmingham for the first time ever and checked into the Cabana Motel. The Cabana provided a central location in the heart of the city and was only two blocks from the downtown stores and main offices of Alabama's two largest department store chains which were to be my prime targets.

I was given a bit of background information on the status of the boycott in Birmingham. In months past, ACWA representatives accompanied by local labor officials had met with managers or executives of the many retail outlets selling Farah slacks to try to persuade them to cut back on their Farah orders. Nothing much resulted from those meetings other than adding to the frustrations already felt by the labor officials involved. Some informational consumer picketing was carried out at certain downtown store locations, but this picketing was nominal only and had no measurable effect whatsoever on Farah sales or the stores policy towards its business relationship with Farah.

The almighty dollar is the real issue or motivating force in the business community. Questions of morality and social justice hardly stand a chance in the business sphere unless they can be defined in the businessman's language. That language speaks in terms of profits and losses measured in dollars and cents. Before a business executive makes any decision regarding the carrying of a certain product, he weighs his decision on a scale of profits and losses. Only when he is convinced that his business has much more to lose than to gain by carrying a struck product will he stop stocking that product. The question of social responsibility never enters into his decision.

The businessman's primary concern is the continued growth and success of his business. If anyone mounts a real threat to this continued growth and success, the business executive will respond to pressures fast. But big businessmen are not fools.

They are not going to let themselves be bluffed into making rash decisions. Thus when small and obviously powerless groups of labor officials or other community members set out to convince business leaders, through either moral persuasion or implied threats, to terminate profitable business relationships such as those which existed with the Farah Company, their efforts in most cases are doomed from the very start. You can not confront executives of powerful institutions and expect to gain any kind of meaningful concessions from them without first being backed by a significant force of power yourself. To confront your adversaries otherwise probably 99 times out of 100 is a total waste of time and energy and only leads to greater frustrations and a weakening of your position. You must negotiate from a position of strength and power or not try to negotiate at all. A good student will not face exam time without first doing his homework and preparing for it. To do otherwise would be a lesson in futility. A good organizer will not face negotiating time without first doing his homework and preparing for it. To do otherwise would also be a lesson in futility.

Prior to heading South, I was told that no stores in Alabama, except for the Pizitz chain, were in any way cooperating with the union's boycott efforts. Pizitz is Alabama's largest department store chain with seven stores (5 located within a 25 mile stretch in the Birmingham area and two others 100 miles away in Montgomery and Huntsville). My understanding was that Pizitz had stopped advertising Farah and had cut down considerably on their Farah orders and sales. On the other hand, I was informed that Loveman's which is Pizitz's major competitor and Alabama's second largest department store chain with five stores (3 located within a 25 mile stretch in the Birmingham area and two others 100 miles away in Montgomery and Huntsville) in no way shared labor's concerns and refused to cooperate with the boycott in any way. In fact a few months earlier labor leaders had met with a manager of one of Loveman's

men's departments. They were treated very rudely by him and informed that Loveman's would order and sell all the Farah slacks it could and if local labor officials didn't like it that was too bad. They could go out the same way they came in. Other stores took a similar hard line position. Needless to say, the labor officials were upset at the responses they received but at this point in time really were in no position to deal with the situation effectively.

When I arrived in Birmingham and got my first look at Pizitz and Loveman's, noting that each store in the two chains represented nearly a whole city block, I asked myself, how the hell am I ever going to deal with those giants? On the surface, the job appeared to be impossible since I had no staff and was starting from scratch in an area totally unfamiliar to me. Yet at the same time, I was confident that I could find a way to break them (force store executives to sever their business relationships with Farah). I began to conceive of my game plan and in early January, with indications of widespread support mounting, I informed union headquarters that by mid-February I expected to break or at least be on the verge of breaking Pizitz or Lovemans.

Throughout the country, Farah boycott organizers were trying to put the domino theory into effect. By that I mean organizers would try to break the largest store in their area realizing that soon thereafter other stores would follow suit rather than attempt to ward off pressures that the largest and mightiest store or store chain among them could not do. The theory is fine on paper and will work provided the organizer can develop the power base and campaign strategy that is potent enough to force a move on the part of the biggest and most powerful target. The reason the domino theory is rarely worked to perfection is because organizers rarely build the power base and campaign strategy necessary to completely annihilate the biggest target. Instead, because of a lack of technical organizational skills and concepts

4

and certain other factors, organizers of boycotts will consistently rely on the same, old, unimaginative harassment tactics like protest rallies and scattered confrontations rather than attempt to build real power through widespread community organization and well planned and researched campaign strategy. Their entire efforts are based on a form of gorilla warfare with no real direction or muscle behind them. Such tactics alone make poor strategy for confronting powerful institutions. They have their place when carried out in the proper setting and at the proper time but in other respects they are worn out, worthless movers <sup>which usually</sup> ~~that~~ accomplish no more than to allow some, at best, to vent their pent-up frustrations (We showed them how we feel even though we did not get the job done).

When I got to Birmingham, I decided to take on the biggest, most powerful targets first and make the domino theory work for me. However, I took an entirely different approach than did other organizers to <sup>accomplish</sup> ~~get~~ the job ~~done~~. As I describe this approach it is not to belittle the approaches and many months of dedicated and effective work other organizers and supporters of the boycott did. But it is to give an example of what proved to be a 100% effective approach. An example which needs to be documented because of its unusual success and because of the concepts and ideas which when scrutinized can be adapted for use by other organizers in their efforts.

As soon as I arrived in Birmingham, I studied the area geographically, mapped out my prime targets and listed and mapped out the locations of all my potential sources of support. I figured there were four areas from which I could draw my base of support: first labor organizations, then clergy, certain community organizations and college students. I talked to many people and tried to learn as much about the community as I could especially with respect to my targeted businesses and their relations with labor and minority groups. From my many conversations, I picked up bits and pieces of information regarding the community and the many personalities

with whom I was interacting. These pieces of information proved invaluable to the overall strategy and continuing progress of the boycott campaign and in my dealings with persons in the business, labor, and religious communities.

I set up meetings with and dropped in on ~~the~~ labor officials. I learned quickly who the most influential labor leaders were and made it a point to gain their total confidence and support before broadening my base. I learned early not to count too heavily on clergy support in the deep South as most were fundamentalists and would not think too highly of my reasons for being in Alabama. However there were a few clergymen whom I felt would be strong potential allies. I made it a point to contact them and although they may never realize it, they played a significant role in the quiet success of the boycott. <sup>(see appendix I, Pgs 78-81)</sup> The great potential source of resources lying dormant in the academic community and in certain community organizations never had to be tapped. Although I did begin to make inroads into these areas, I never really started focusing in on either of them for support. As my campaign resources were building and my campaign psychology was developing, I realized that the role certain clergy were playing and the tremendous support I was assembling from organized labor would be enough to get the job done.

It wasn't long after my arrival in Alabama that my mind was made upon 3 points. First, I totally disagreed with the national office's suggestion to form a small committee of labor officials to meet with the different retailers to ask them to make concessions regarding their business relationships with Farah. Such a committee had had no success in the past and there was absolutely no reason to believe that one would fare any better now. If another such gathering were held one or two things probably would have happened. The small group of labor officials would have been forced to swallow their pride after fruitlessly pleading their case on the basis of ethics or they might have made a series of rash statements and implied threats which they and the retail executives knew could not be backed up and would soon blow over. I remain

*before confronting on*

*I*

fully aware that when ~~you~~<sup>^</sup> your adversary to negotiate you must have a real sense of power in ~~your~~<sup>my</sup> own corner otherwise ~~you are~~<sup>I am</sup> nothing more than a pleading inferior who can talk til blue in the face and accomplish absolutely nothing<sup>but</sup> to further weaken ~~your~~<sup>my</sup> position.

Secondly, I wanted nothing to do with paying a few pickets to stand in front of an entrance of one of these mammoth chain stores a few hours a week. Such is symbolic only of the union's feeling but carries little or no weight in the long run. A picketing program like any other aspect of organization can be very effective but only if done according to a well planned, systematic operation.

Thirdly, I felt that I should never have to make initial contact with executives of my first targeted store chain. Since the big money powers always know what is happening in their community <sup>especially</sup> specifically if it affects their economic interests they would get in touch with me provided I did my job effectively. Specifically, if I built a strong power base and campaign strategy that loomed as a real threat to their economic well being, the store executives would seek me out quickly. At that point I would know that I could begin to negotiate from a real position of strength. The status quo would have indicated that it was finally ready to do some serious listening.

Ironically, when I was sent to Alabama in mid-December, I was under the assumption that I could expect to do little more than get myself settled since Christmas holiday season was the worst possible time to make any headway in contacting union members. However, as I met with one labor official after another, I learned that a number of the unions were holding parties and that I might ask for five minutes at these parties to introduce myself and to say a few words. As luck would have it, these gatherings were well attended and thus offered a good opportunity for me to meet a lot of people and to make my presence known. More importantly, I found that at Christmas time labor officials could be found in their offices with plenty of time for discourse since they weren't on the road tied up in negotiations or on other business.

Warm and friendly responses were extended to me from nearly all labor and church officials with whom I met. To each individual and group I spoke I made the total commitment of the ACWA as well as my own personal commitment clear. I emphatically stated that the ACWA had sent me to Birmingham to clear all Farah slacks from the area and that I could not and would not leave until the job was done. I also built up the importance of the campaign and simultaneously laid a heavy burden and challenge on Alabama labor officials by making everyone aware that the ACWA felt Farah would give in if we could totally wipe his business out of a major southern market like the Birmingham area.

I developed a pitch and tried it out on a few labor people at a time to check the type of reaction I might expect before using it in addressing larger audiences. The labor officials not only agreed with what I was saying but showed a great deal of concern. I then set up as many speaking engagements as possible at union membership and executive council meetings and hammered away hard with my message. This was the beginning of constant activity: making contacts, following-up and continually evaluating the progress of the campaign. From here on, the campaign had to build, it could never slow down.

In the campaign approach to organizing life is viewed as a game of numbers and it is understood that a percentage of any population will lend its active support to a cause. The amount of support generated in campaign organization will depend upon the receptiveness of the audience or segment of the population contacted as well as how effectively the organizer's message is delivered. Thus a campaign organizer builds a numbers power base by systematically contacting large numbers of people, but only, in those areas which prior research indicates are populated by persons whose self-interests, political or ideological consciousness parallel his own. From these targeted areas supporters are recruited, activated and their efforts coordinated in the professional manner necessary to reach a certain objective.

Any organizer who sets out to build a campaign organization must be ready to point out in specifics how volunteers can become meaningfully involved in the overall strategy of the campaign. And people must be able to fit this involvement into their life styles. In other words volunteers should not be expected to make great sacrifices or to change their life-styles to fit the needs of the campaign. Every well structured campaign will generate its share of ardent and capable supporters who will expend large amounts of time helping to coordinate all aspects of the campaign but massive campaigns are built mainly on the energies and small commitments of hundreds or thousands of persons, each doing a small part in a concerted, well planned systematic effort that builds into an increasingly powerful and effective force. Volunteers in campaign organization are viewed as individual building blocks, who depending upon their commitment, available time, and skills can be fit into some aspect of the campaign structure and can play an important role without ever having their normal life styles infringed upon.

Everytime I met or spoke with any sympathetic person or group, I distributed volunteer sheets knowing that I could expect a certain percent of them to be returned. These returns marked the beginning of building my power base and source of committed manpower. Perhaps the greatest volunteer I will ever have recruited from a volunteer sheet is Jane Holcombe. Jane worked for the Alabama Labor Council and filled out one of the volunteer forms which I gave to the council's president who in turn distributed them to each person in his office.

Jane signed up to volunteer a couple of evenings a week. She soon found herself making a total commitment to the campaign by volunteering all of her available time day and night seven days a week aiding me in all aspects of putting and holding the campaign together. From the very outset of the campaign, Jane spent untold hours doing the vast amounts of typing, printing, and mailings that were necessary. She kept in daily contact with every facet of the boycott as well as compiled and constantly revised and updated lists of all Farah supporters and officers of labor organizations. At each labor leaders conference, she and her sister Kathy, greeted everyone, recorded



a profile on them and acted as recording secretaries.

In my years of organizing experience, I have worked with some people who I feel are rightfully deserving of high esteem and recognition because of the professional caliber and selflessness with which they do a job in behalf of humanitarian concerns. Jane is one of those people. Without a unique person of her capabilities, the Farah Boycott Campaign would never have succeeded the way it did.

The following volunteer sheet for our general file was structured to make it as convenient as possible for persons to make some type of volunteer commitment to the campaign. Volunteers could check off what times each day they most likely would be available and the specific activities of involvement that most interested them. They could also choose to work from within their homes or in areas close to their homes. As we developed our volunteer force and categorized persons according to days and times available, work preferences, and geographical area, we could constantly evaluate areas of weakness of our campaign structure and recruit accordingly. The following is a copy of the general file Farah Boycott volunteer sheet:

I PLEDGE TO ACTIVELY SUPPORT THE FARAH BOYCOTT

Name \_\_\_\_\_ Age \_\_\_\_\_

Home Address \_\_\_\_\_

Phone \_\_\_\_\_ Occupation \_\_\_\_\_

I may be available to help at the following times:

Mornings \_\_\_\_\_ Afternoons \_\_\_\_\_ Evenings \_\_\_\_\_

Monday \_\_\_\_\_

Tuesday \_\_\_\_\_

Wednesday \_\_\_\_\_

Thursday \_\_\_\_\_

Friday \_\_\_\_\_

Saturday \_\_\_\_\_

I would like to help the Farah Strikers by Volunteering the following types of support:

Picketing - with a group at the stores selling Farah slacks.

Canvassing - making door-to-door visits explaining boycott.

Telephoning - persons to draw awareness to boycott.

Office work.

Anything I can do to be most helpful (you may be called for any of the above activities or other actions).

Comments or Suggestions:

I Live Closest To:

THE PIZITZ STORE LOCATED AT:

1. 1821 2nd Ave. N. (Downtown) \_\_\_\_\_

2. 1917 2nd Ave. N. (Bessemer) \_\_\_\_\_

3. Five Points West Shopping Center \_\_\_\_\_

4. Eastwood Mall (Highway 78) \_\_\_\_\_

5. 9118 Parkway E. (Roebuck) \_\_\_\_\_

THE LOVEMAN'S STORE LOCATED AT:

1. 216 19th St. N. (Downtown) \_\_\_\_\_

2. Westlake Mall \_\_\_\_\_

3. Western Hills Mall \_\_\_\_\_

VOLUNTEER ASSIGNMENTS COMPLETED:

1. \_\_\_\_\_

2. \_\_\_\_\_

3. \_\_\_\_\_

4. \_\_\_\_\_

5. \_\_\_\_\_

Recognition Granted \_\_\_\_\_

PLEASE FILL IN AND MAIL THIS FORM TO:

Farah Slacks Boycott Committee  
ACWA North Alabama Joint Board  
220 South 43rd Street  
Birmingham, Alabama 35222

//

There was a certain pitch or theme I reiterated over and over again as I confronted labor union members at one meeting after another. I kept hammering away with: "I just completed a survey of Farah slacks in the Greater Birmingham Area and you know what I found? I found that there are enough Farah slacks on sale in the Greater Birmingham Area alone to keep Willie Farah in business indefinitely. Now I've been told by steelworkers and other union members that labor owns Birmingham. If what they say is true, if labor does own this town, then labor also owns all the damn Farah slacks in this town and they'd better get them the hell out of here. I came to Birmingham with the commitment from the ACWA that I would not leave here until the Greater Birmingham Area was cleared of Farah slacks and I'm not leaving until the job is done. ~~Now~~ To get the job done, I need your help. If I can not get your help, I might as well leave now. This is both a moral issue and a labor issue and not only do I need your help but I expect your help. You'll either volunteer your help or else one of two things is going to happen. I'll harrass the hell out of you until you either help me get the job done or else you throw me out of town. That's how serious I see this issue to be. Now when I was sent to Birmingham, the national office informed me that the Loveman's chain was to be my main target, the reason being, that of the two largest department stores selling Farah, Pizitz they thought was somewhat friendly and cooperative whereas Lovemans remained very anti-labor and uncooperative. Well I just completed my own survey of the five Pizitz stores and the three Lovemans stores in this area and you know what I found? I found that either one of at least two Pizitz stores have as much or more Farah slacks on sale than all three of Lovemans' stores combined. Now when someone is my adversary and they tell me they are my adversary and will challenge me, I respect them for their honesty. But what concerns and aggravates me is when someone tries to make out that they are my friend and then stabs me in the back. As far as I am concerned, that is what Pizitz has done to

labor in this state. Pizitz management tells labor one thing but their actions indicate just the opposite. And actions speak louder than words. Pizitz says they've been cooperative with labor on the Farah issue! Yet in there five local stores Farah is their #1 brand of slacks representing 60-85% of their entire stock. For these reasons ladies and gentlemen, Pizitz must be dealt with first and thus has become the prime target."

As I got deeper into the campaign I changed and added to my pitch: "Last year Birmingham was named the All America City and that's something to be proud of. But right now I have another name for it, Scab City USA because there are more Farah slacks on sale per capita in the Greater Birmingham Area than probably anywhere else in the country. And it will stay Scab City USA until we clear those damn Farah slacks out of here. You know, when steelworkers work for steelworkers interests we have a steelworkers movement, when mineworkers work for mineworkers interests we have a mine-workers movement and so on down the line, but it is only when labor groups work together for social, economic and political goals that we truly have a viable labor movement working for people's interests. And that is what our campaign needs behind it, a labor movement where each union does its part to put an end to the tragic conditions prevailing at Farah."

After making an extensive number of personal visits and phone calls to labor officials and speaking engagements to labor organizations, I reached the point where I felt #1 that the majority of the area's influential labor leaders had made a commitment to me to lend whatever support their time would allow to build a successful boycott and #2 that rank and file union members could be turned on in large numbers to actively lend their support. I then decided it was time to bring all the labor officials together to openly make a joint commitment to actively support a formalized boycott campaign. This campaign would be structured much along the lines of a political campaign, systematically planned to build according to a timetable or series of deadlines to assure continuity, progression and accountability.

After Thermon's letter was sent out, I figured that it needed a lot of muscle to back it up. Thus a second letter was sent out on January 9th and signed by 10 of the most influential labor leaders in the area including the ranking officers of the largest AFL-CIO labor unions and the highest officials of the two large independents, the United Mine Workers of America and the United Auto Workers. Again I prepared the letter and had the president of the Alabama Labor Council pass judgment on it. After procuring a couple of signatures for the second letter, I called the next official and said "so and so" signed a letter which is in support of the January 3rd letter you received from Thermon Coggins. I want the signatures of 10 of the most respected and powerful labor leaders in Alabama on this second letter to back up Thermon's call to action. That's why I am calling you because it's important for me to have your signature alongside that of Barney Weeks (President, Alabama Labor Council) and Howard Strevel (President, United Steel Workers of America District 36, Alabama's largest union). Each labor official gave me the okay to use their signature and the second letter with eight pages attached to it was sent out on January 9th to all other labor officials. That letter and the eight attachments follows:

16  
NORTH ALABAMA AREA JOINT BOARD

*Amalgamated Clothing Workers of America*

220 43RD STREET, SOUTH

BIRMINGHAM, ALABAMA 35222

TELEPHONE 595-7886



January 9, 1974

Dear Brother:

Recently in a letter from Brother Thermon Coggins, President of the Birmingham Labor Council, we were reminded of the tremendous quantities of scab Farah pants being sold in retail outlets throughout the Greater Birmingham Area.

This is a serious issue. One which we can not ignore.

All of us in organized labor must confront ourselves with these haunting questions: How can Birmingham's major retailers so blatantly disregard labor's concerns by stock-piling Farah products? Do they consider labor as a force that must be reckoned with? Or do they view labor as the meaningless, ineffectual type of organization which carries a name only but no power?

Will organized labor sit back meekly while daily injustices continue right under our noses?

We state emphatically no! Either Willie Farah and his Birmingham cohorts are going to make fools of us all or else Birmingham is going to be cleared of Farah products until the Farah strike is settled.

This is our position and no compromises can be made.

We too, with Brother Coggins, cannot emphasize too strongly the importance of the Wednesday, January 16th meeting at the Birmingham Labor Council Hall and the necessity of your presence.

Fraternally,

*Willard W. Brown*

Willard W. Brown, Int'l V. P.  
Communication Workers of America

*Bruce Carr*

Bruce Carr, Int'l Rep.  
Laborers International Union

*Hayes W. Cockrell*

Hayes W. Cockrell, B. A.  
IB of EW Local 136

*Donald Cromer*

Donald Cromer, Int'l Rep.  
United Auto Workers

*Benny Dansavage*

Benny Dansavage, State Dir.  
ILGWU

*Sam Littlefield*

Sam Littlefield, Pres., Dist. #20  
United Mine Workers of America

*Horace Moore*

Horace Moore, President  
Carpenters District Local

*Howard Strevel*

Howard Strevel, District Director  
Steelworkers of America

*Barney Weeks*

Barney Weeks, President  
Alabama Labor Council, AFL-CIO

*C. T. Daniel*

C. T. Daniel, Int'l Rep.  
RWDSU

## THE GREATER BIRMINGHAM FARAH BOYCOTT CAMPAIGN

### Purpose

The purpose of the Farah Boycott Campaign is twofold. First to inform the public of the issues surrounding the boycott so that consumers will stop buying Farah products. Secondly and most importantly, to gain the cooperation of the major retailers of Farah products such as Pizitz and Loveman's to remove all scab Farah clothing from their shelves and to cancel future Farah orders until the Farah strike is settled.

### Problems With Some Retailers

In seeking the cooperation of some retailers, we know from past experience that we will run into some difficulties. We would like to think that by appealing to a retailer's sense of morality and social justice that we could expect to gain his full cooperation. Unfortunately, some people within the business community, like many other communities, although reputable citizens, are not always moved by moral persuasion unless it is colored in dollars and cents, namely: How much have they to gain or lose? Only when they are convinced that they have more to lose than to gain by not cooperating with labor's legitimate requests will they cooperate. Of course, we are now getting away from real moral persuasion and into the politics of power.

### Politics of Power

What the politics of power boils down to is: how much pressure can labor mount vs. how much pressure can the opposition endure? We know that no politician or businessman can sit on a hot issue if it becomes hot enough. Thus certain businessman must come upon the realization that some 70,000 laborers in this area have the power to compel cooperation, if necessary; that organized laborers in the Birmingham area and throughout the state are not pleading inferiors to be satisfied with less than what human dignity mandates.

### Boycott Coalition

The full power behind the campaign will be the concerted efforts of labor organizations, religious leaders, student groups, and certain community organizations into a well planned, systematic boycott approach. For example, suppose that the Farah boycott activities first focus around the 5 local Pizitz Department Stores. Such a campaign should entail the following:

1.) Pickets everyday at every entrance into Pizitz 5 department stores (see diagrams on pink sheets). It is expected that the many labor organizations in the Birmingham area can furnish the required number of pickets everyday until the targeted retailers agree to cooperate. (For retailers to cooperate, they must remove all Farah products from their shelves and cancel future Farah orders until the strike is settled.)

Labor organizations might be grouped together so that perhaps 10-15 organizations may be assigned to one store and 10-15 to another, etc. It will be the responsibility of each group of labor organizations to set up a steering committee whose

job will be to generate the manpower to walk that picket line for as long as necessary. It will be the ACWA boycott organizer's job to inform the local police of daily boycott activities and to furnish instructions to pickets, as well as the picket signs and thousands of pieces of boycott literature which will be handed out to consumers. At each picket site, every effort will be made to have at least one member of the clergy present in support of the picket.

2.) Telephone banks and door-to-door canvassing operations constructed to relay the boycott message to residents throughout the Birmingham area. Many students as well as concerned community citizens apart from the labor movement will be taking part in building boycott pressure through these types of direct person to person contact.

3.) Public relations activities will continue throughout the campaign by holding speaking engagements and showings of the film "The People vs. Willie Farah". At all such gatherings, volunteer sign-up sheets (see copy enclosed) will be distributed. This way, the campaign will constantly be building its general volunteer workforce which can be used to supplement all facets of campaign activities.

Business to be Covered Wednesday Night - January 16, 1974

- 1.) Making a record of everyone present
- 2.) Presentation and discussion relating to proposed campaign strategy
- 3.) Agreement by labor groups to actively support a Farah Boycott Campaign
- 4.) Breaking labor organizations up into groups and assigning picket responsibilities
- 5.) Deciding upon a series of timetables for mobilizing campaign forces and initiating campaign
- 6.) Assigning a group to follow-up on any organizations which do not send a representative to the meeting

\* Beginning promptly at 7:00 p.m. prior to the business meeting will be the 20 minute film, "The People Vs. Willie Farah."



# PIZZITZ

(1) 1821 2nd Ave N (downtown)

Open 10:00 - 8:30 Mon + Fri; 10:00 - 5:30 Tues, Wed, Thurs, + Sat  
18 Pickets

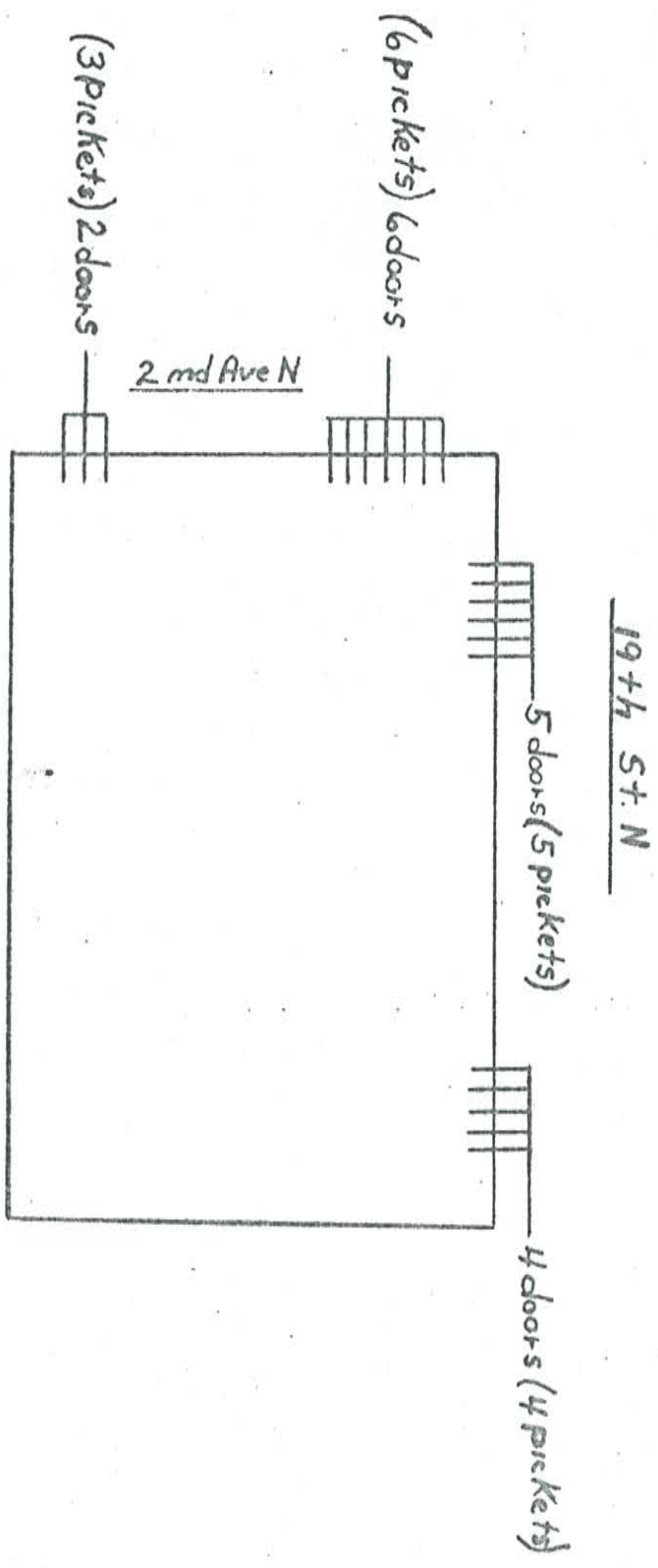

# PIZZITZ

(2) Five Points West Shopping Center

Open 10:00 am - 9:00 pm Mon-Sat

17 Pickets

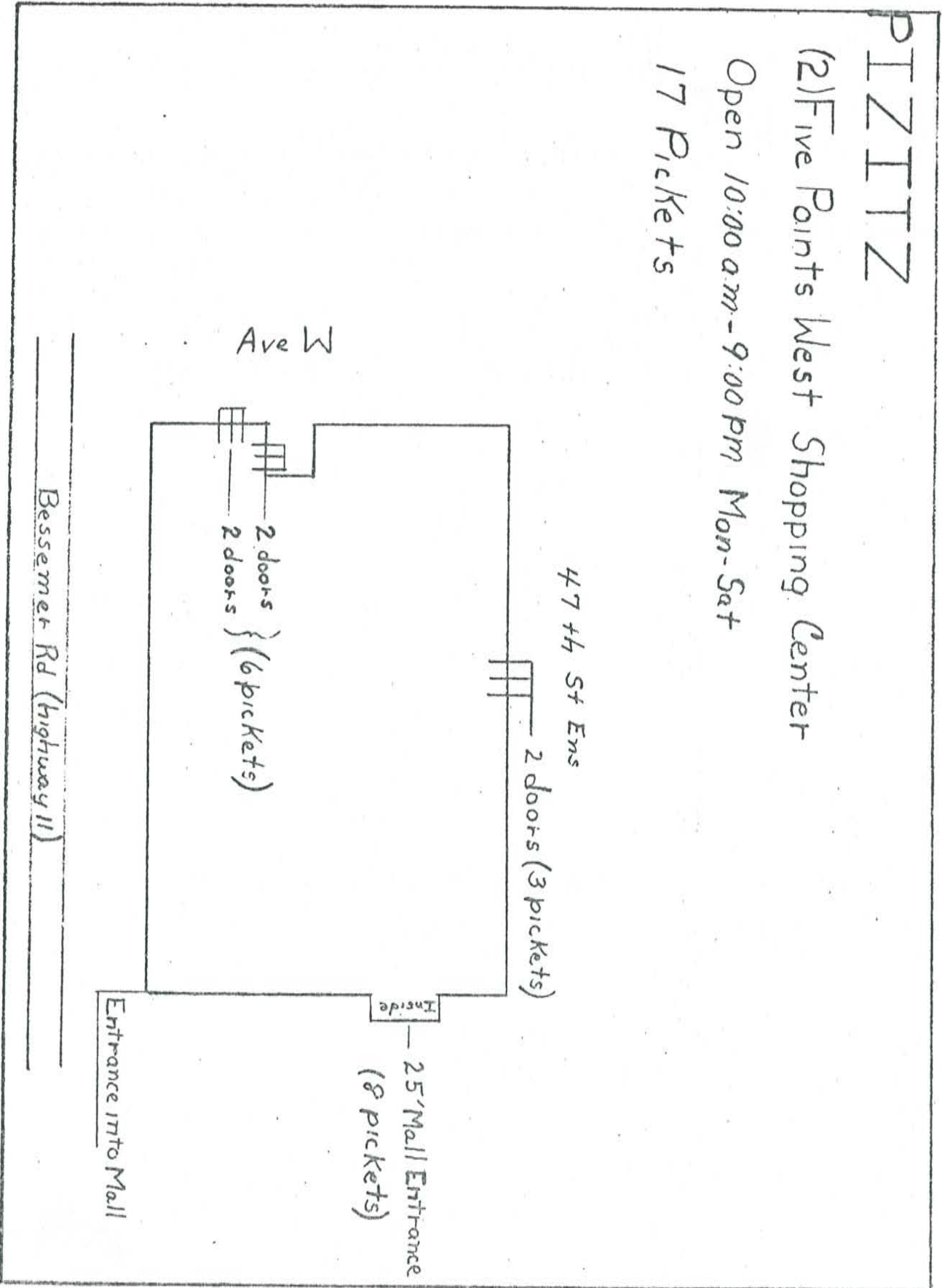

# PIZZITZ

(3) 1917 2nd Ave N - Bessemer

Open 10:00 a.m - 9:00 PM Mon - Sat

13 Pickets

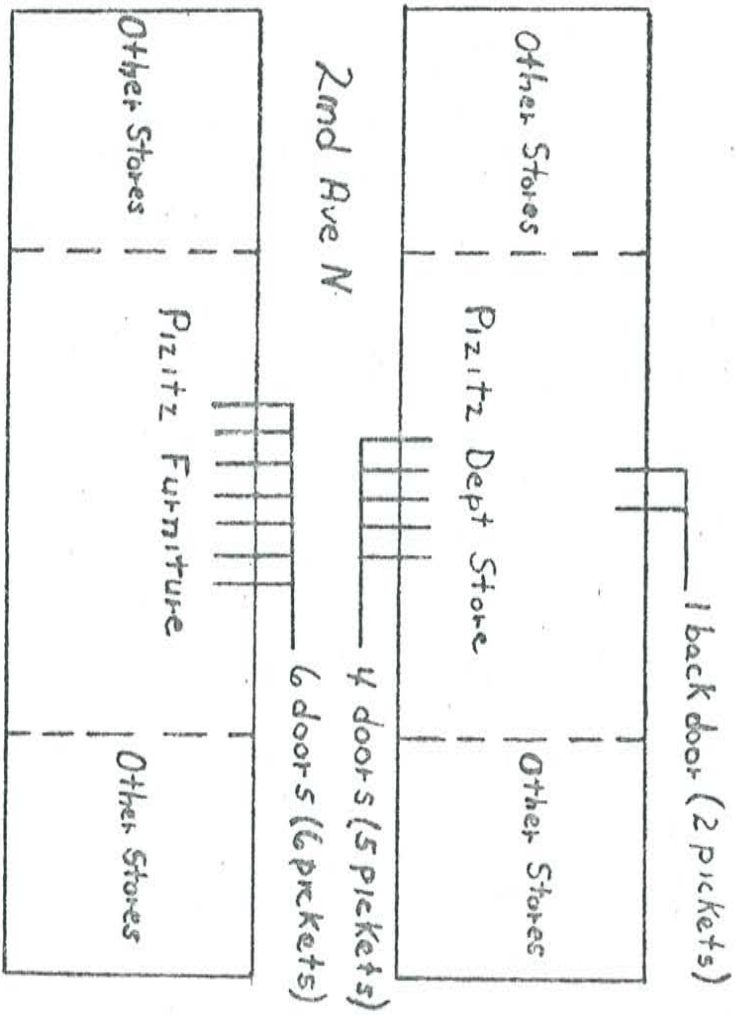

# PIZZITZ

(4) Eastwood Mall (Highway 78E)

Open 10:00 a.m. - 9:00 PM Mon - Sat

20 Pickets

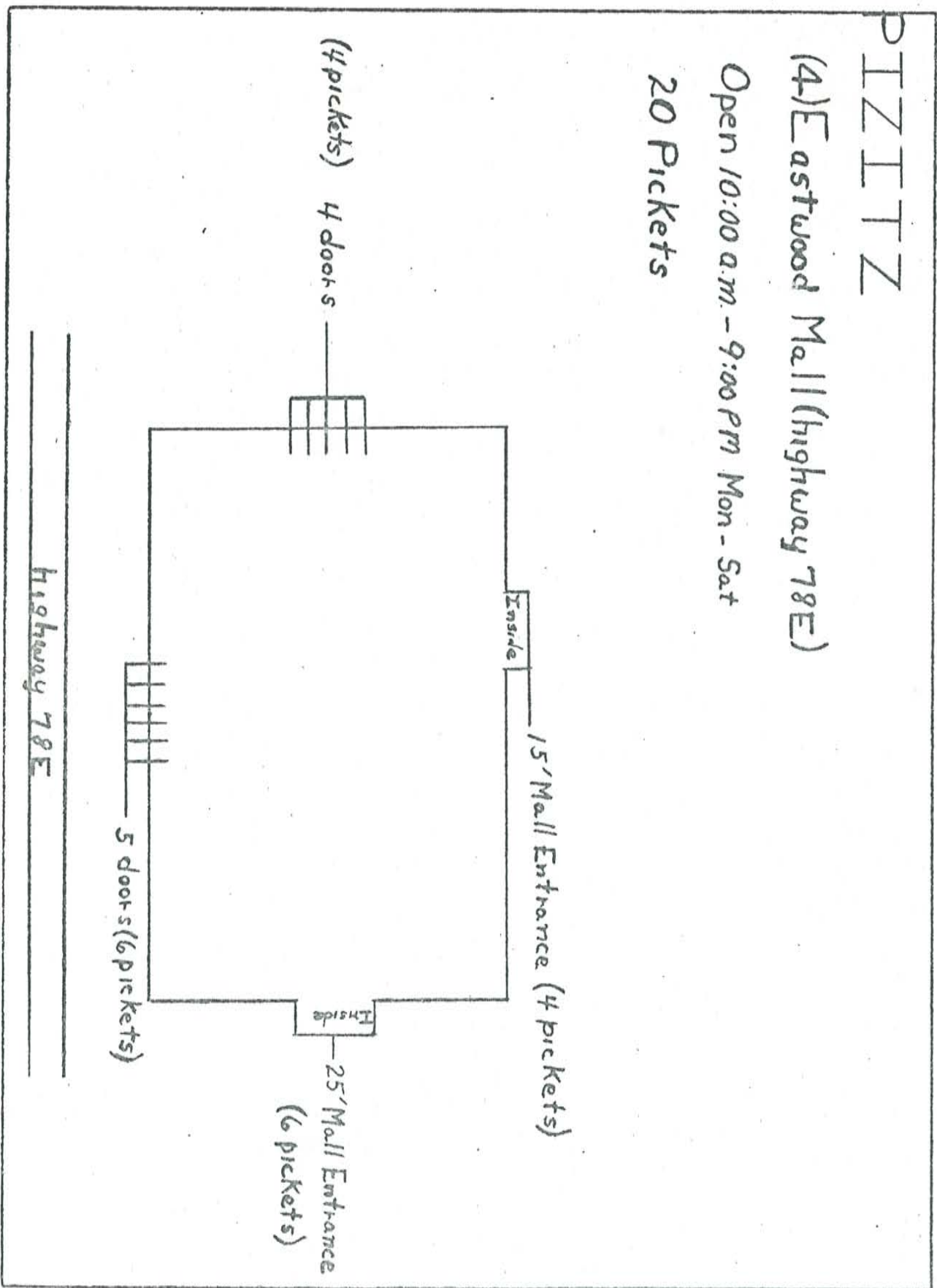

# PIZZITZ

(15) 9118 Parkway E - Roebuck

Open 10:00 a.m - 9:00 p.m Mon - Sat

19 Pickets

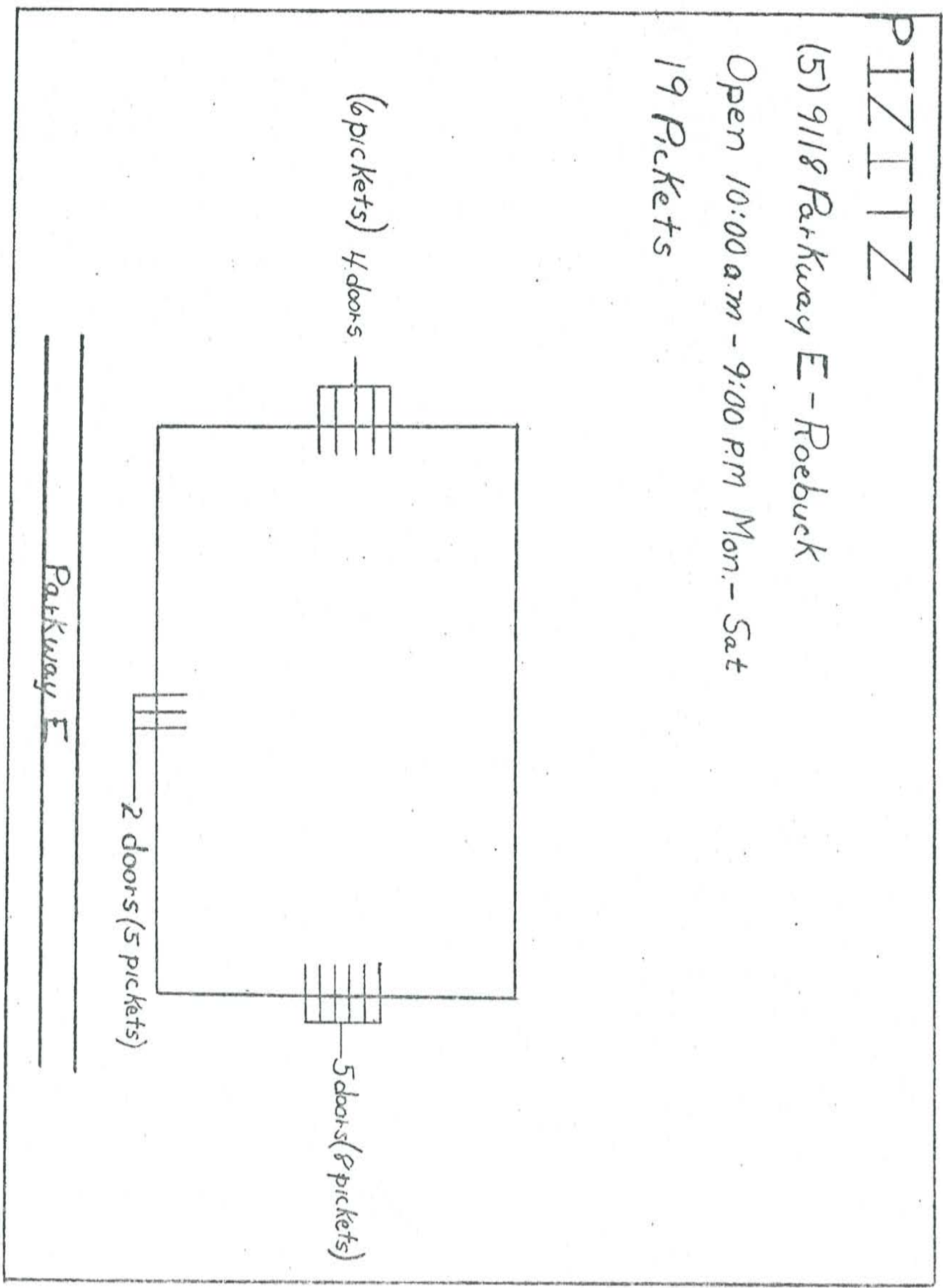

I PLEDGE TO ACTIVELY SUPPORT THE FARAH BOYCOTT

Name \_\_\_\_\_ Age \_\_\_\_\_

Home Address \_\_\_\_\_

Phone \_\_\_\_\_ Occupation \_\_\_\_\_

I may be available to help at the following times:

Mornings \_\_\_\_\_ Afternoons \_\_\_\_\_ Evenings \_\_\_\_\_

Monday \_\_\_\_\_

Tuesday \_\_\_\_\_

Wednesday \_\_\_\_\_

Thursday \_\_\_\_\_

Friday \_\_\_\_\_

Saturday \_\_\_\_\_

I would like to help the Farah Strikers by Volunteering the following types of support:

\_\_\_\_\_ Picketing - with a group at the stores selling Farah slacks.

\_\_\_\_\_ Canvassing - making door-to-door visits explaining boycott.

\_\_\_\_\_ Telephoning - persons to draw awareness to boycott.

\_\_\_\_\_ Office work.

\_\_\_\_\_ Anything I can do to be most helpful (you may be called for any of the above activities or other actions).

Comments or Suggestions:

I Live Closest To:

THE PIZITZ STORE LOCATED AT:

1. 1821 2nd Ave. N. (Downtown) \_\_\_\_\_

2. 1917 2nd Ave. N. (Bessemer) \_\_\_\_\_

3. Five Points West Shopping Center \_\_\_\_\_

4. Eastwood Mall (Highway 78) \_\_\_\_\_

5. 9118 Parkway E. (Roebuck) \_\_\_\_\_

THE LOVEMAN'S STORE LOCATED AT:

1. 216 19th St. N. (Downtown) \_\_\_\_\_

2. Westlake Mall \_\_\_\_\_

3. Western Hills Mall \_\_\_\_\_

VOLUNTEER ASSIGNMENTS COMPLETED:

1. \_\_\_\_\_

2. \_\_\_\_\_

3. \_\_\_\_\_

4. \_\_\_\_\_

5. \_\_\_\_\_

Recognition Granted \_\_\_\_\_

PLEASE FILL IN AND MAIL THIS FORM TO:

Farah Slacks Boycott Committee  
ACWA North Alabama Joint Board  
220 South 43rd Street  
Birmingham, Alabama 35222

The attachments to the letter were important for psychological reasons. The letter certainly was worded strongly and was signed by the right people. But the letter alone I felt was not enough. Besides the strong verbal commitment from labor leaders, a message had to be relayed that this commitment was backed by a specific, well planned strategy that could back up the verbal commitment of "Either Willie Farah and his Birmingham cohorts are going to make fools of us all or else Birmingham is going to be cleared of Farah products until the Farah strike is settled."

The two page description of the proposed Farah Boycott Campaign and business agenda as well as the attached store diagrams and volunteer sheet exhibited that real planning and professionalism was behind the present boycott effort. That a whole new and unique concept for organizing the boycott was in the making and the persons organizing it and backing it meant business.

By dealing in specifics, not generalities, it enabled those receiving the letter to perceive what the campaign was all about and that as a structured campaign, there would be a foreseeable beginning and ending. The Pizitz diagrams depicted the fortress of a real adversary. It wasn't imaginary. It was Pizitz. The target was frozen. The agenda began by making a record of everyone present and ended by assigning a group to follow up on any organization not represented. A showdown was coming and everyone in the labor movement was going to be held accountable.

To sum up, the second mailing helped instill confidence in those receiving it that there was a real sense of direction behind the boycott effort. That whoever was organizing it knew exactly what they were doing. Labor leaders were beginning to feel that 'something big is about to happen and by God we want to be in on it.' One last point of psychology: Can you imagine the expression on the faces of Pizitz management when they happened to get a copy of the letter and its attachments?

The January 9th letter was received on Thursday or Friday the 10th or 11th.

26

On Monday the 14th, two days before the conference every labor leader was called and asked point blank who would be representing their organization at the conference. By studying the following January 14th telephone message you'll note that whatever response our caller might receive, she was prepared to respond quickly and in such a manner as to assure, as much as possible, her gaining a commitment from the labor official.



Monday's Phone Call

Hello (Mr/Ms \_\_\_\_)

This is (your name) with the Farah Slacks Boycott Campaign. I am calling about the meeting of all Greater Birmingham labor organizations this Wednesday night at the Birmingham Labor Council. (Mr./Ms \_\_\_\_ ) I'd like to find out who will be representing (name of local) at the meeting.

(Gives name)

Thank you (Mr/Ms \_\_\_\_). Everyone in the Farah Campaign certainly appreciates your concern. We will look forward to meeting (you or \_\_\_\_ ) Wednesday night. Good-bye.

(Does not know about meeting)

I am sorry (Mr/Ms \_\_\_\_). As president of your local you should have received information about the meeting of all labor leaders in the Birmingham area. Let me briefly describe to you why the meeting has been called.

In an effort to clear Birmingham of all scab Farah pants, eleven Birmingham labor leaders sent letters to all union executives calling them or a designated representative into an emergency meeting to discuss concrete plans for a boycott campaign against scab Farah products. The meeting will be held at the Birmingham Labor Council, 1712 7th Avenue North this Wednesday night at 7:00 p.m. (Mr/Ms \_\_\_\_ ) let me have your address and I will have an agenda of the meeting sent to you right away.

(Gives Address)

Thank you (Mr/Ms \_\_\_\_). The Farah Strikers need the support of Birmingham's labor leaders. I hope we can count on you local being represented at Wednesday night's meeting. Good-bye.

(I or my local has a meeting that night and will be unable to attend).

Well of course (Mr/Ms \_\_\_\_ ) we understand that Wednesday night's emergency meeting might conflict with the busy schedules of some labor leaders. However, we do hope that your local can designate at least one person to attend this very important meeting.

I am sure you are aware of the Farah strikers' tremendous struggle and the need for all Birmingham labor leaders to actively get behind them. Can we count on your organization to send a delegate Wednesday night.

(Yes)

Thank you (Mr/Ms \_\_\_\_). Everyone in the Farah Campaign certainly appreciates your concern. We will look forward to meeting (you or \_\_\_\_ ) Wednesday night. Good-bye.

(Not sending a representative)

Well (Mr/Ms \_\_\_\_ ) I am sorry to hear that. Of course you understand that in order for Birmingham to be cleared of scab Farah clothing, we need the support of all labor groups. We hope that you will reconsider as your support is greatly needed. Thank you for your time. Good-bye.



In every detail the campaign was scientifically and systematically built. On Wednesday, the day of the conference the following simple reminder call (a kind of get out the vote call) was made to every labor official:

Wednesday's Phone Call

Hello (Mr/Ms\_\_\_) (If the person you are trying to contact is not there, leave the message with whomever answers the phone).

This is (your name) calling for the Farah Boycott Campaign to remind you about tonight's meeting at the Birmingham Labor Council of all area labor leaders. The 20 minute film, "The People vs. Willie Farah" will begin promptly at 7:00 p.m. The business meeting will begin immediately thereafter. Thank you for your time. Good-bye.

The mailings, the phone calls, the personal visits and the constant activity about them, pulled the labor leaders out of the woodwork and into the conference. Attendance at the conference was an overwhelming 71 representing 20 internationals and the state and local labor councils. My sentiments before the conference were that if 25 of the right people showed up, the Greater Birmingham Area and Alabama were on their way to being cleared of Farah slacks. *(see appendix II, Pgs 82-85)*

In looking back, as the campaign progressed to where the heavy recruitment of pickets began, I was invited to speak at the Shopman's Local. The president, Ralph Goodwin, before introducing me, described to the membership how he initially had become so interested and involved in the Farah Campaign. He said, "A few weeks back I received a letter about the Farah Slacks Boycott from Therman Coggins and another follow-up letter signed by the big powers in the labor movement. Then as I was answering my second call from someone representing the Farah Boycott Campaign, this guy walked into my office. He emphasized the importance of our local's support for the success of the proposed Farah Boycott Campaign as well as the importance of my presence at the conference that evening. Well I went to the conference and as you

know, I've been involved ever since."

As I previously mentioned, it was my contention that if I were openly active in the community and it became evident through this activity that a powerful force was building which could seriously effect a business' image and severly cut into its profits, then the executive management of the business I was targeting my activities around would initially seek me out for a meeting. If these executives perchance did not contact me, then I planned to call on them just before the campaign was scheduled to strike to give them one opportunity to discuss the type of understanding that labor was seeking and to spell out in detailed, specific terms exactly what the boycott forces were prepared to do if a confrontation situation became inevitable. If Pizitz did not contact me by early February, I felt I would be prepared to call on Pizitz. By being prepared, I mean that I would have, by then, built a solid position of power. Power which could be displayed in numbers of community leaders who openly backed me and the power of having a devastating weapon, in the form of a well researched and structured campaign force, which if the threat of it did not break Pizitz, then the actuality of aiming it and firing it certainly would.

Had I had to initiate a meeting in February I would have gotten my message across in the most intimidating manner possible. I had planned to enter such a meeting with 75-100 labor representatives. This parading of numbers to indicate my power base would have shown how serious the Farah issue was being taken by the labor community and would have acted as a severe warning to business executives that they had better think seriously about severing business ties with Farah. But parading a number power base is not enough when confronting a strong adversary. And big businesses like the Pizitz chain make strong adversaries.

We can gain some valuable insights into boycott conflict by analogizing our situation with military warfare. Before an opposing force will surrender to an army, it has to be convinced that the army has a potent and destructive weapon which will surely be used to annihilate its enemy if the enemy refuses to surrender. In the Alabama boycott, the campaign became labor's potent and destructive weapon. Whether or not it would ever have to be fired would be left up for business executives to decide. And their decision would be based on whether or not they were convinced that the weapon really existed, was corked and would be fired in their direction. An organizer must remember that in warfare, an army with no weapon is weak and will be ignored or destroyed. Likewise, the best arsenal with no army to employ it causes the enemy little concern. Outfit the right army with the proper weapon and the enemy has no choice but to surrender now or else face greater humiliation and perhaps irrevocable injury.

I knew when I entered Birmingham that on a spectrum of power, I stood at zero and the business interests were positioned at the opposite end with all of the power. If on my arrival in Alabama I, with a small committee, had asked powerful business leaders to cancel profitable ties with Farah, they could have told me and the committee to go straight to hell without blinking an eyelash. I could have displayed my weapon but it would have been obvious that I had no army to cork it and fire it. Thus my weapon would not have caused much concern and myself, the committee, and our demands would have been ignored. But the more I did my homework and laid my groundwork, the more I was convinced that positions on the spectrum could be reversed where all the power would be on my end and none on the businessmen's. That point in time is when I had originally planned to request negotiations.

One half hour before the labor leaders' conference was to begin, I was summoned into a back room by Thermon Phillips, of the United Steel Workers of America and

Howard Strevel's second in command. Howard, who sat on the same community boards as Richard Pizitz, had just been called by Richard and Richard asked him to contact me and have me in turn contact him about setting up a meeting. This indicated to me that Richard was both very concerned and worried. In fact the fears of store executives were building faster than my campaign strategy which forced me to push my efforts at an even more feverous pace.

The agenda of the meeting was carried out as planned. I did not mention Pizitz's phone call to Howard Strevel but did mention at the conference the possibility that the next day a meeting of labor officials and Pizitz management might take place. I asked if some of those present could take time off and attend such a meeting the next morning. Because Pizitz had contacted us, I did not feel that the situation warranted my walking in with 50-100 backers but I did want a good show of strength with one representative from a number of the most powerful labor unions. I got the response I wanted and the next morning 21 labor officials including the president of the state and local labor councils and high ranking officers of the largest unions marched with me into Pizitz's office.

One person at the conference I must single out was Jim Freeman, an AFL-CIO Field Representative, who had driven over 200 miles from another meeting in order to attend the conference. When I first met Jim in mid-December, he told me that if the labor people in Alabama saw that I was committed to my job and would stick my neck out, then they would back me up all the way. As the boycott progressed, there was no questioning Jim's insights.

After the labor leaders' conference and subsequent meeting with Pizitz management, Jim told me that he saw something building like he'd never seen before and would try to devote practically full time to the boycott. And that he did, spending hours with myself in negotiations with retailers, in making speaking engagements to labor and community groups and in various other aspects of building the boycott. I found Jim to be a man of unique ability and a perfect partner who knew precisely how to handle

himself in crucial negotiations with retailers. Jim's contribution to the boycott, like that of Jane can not be measured except by stating that without a unique person of his dedication and capabilities, the boycott could not have succeeded the way in which it did.

At about 10:00 O'clock the evening of the labor leaders' conference I called Richard Pizitz at his home. I began my conversation with "Hello Mr. Pizitz. I don't know if you know me by name but this is Ray Rogers and I'm in Birmingham working on the Farah Boycott." Before I got any further, Richard responded that he knew who I was and wanted to set up a meeting as soon as possible. I suggested the next morning at 11:00 AM. This sounded like a good time to him and he asked how many persons I would bring with me. I responded that I might have as many as ten. He responded that he did not think his office was big enough to accommodate ten people. I told him that was no problem, that we would sit on the floor if necessary. He then said that he was not sure whether or not he would be able to meet that next morning. I in turn suggested very strongly that for his own best interests he would make himself available at 11:00 AM. That labor representatives were available at that time. I was very firm and explicit and could tell from Richard's reactions and tone of voice that he realized the seriousness of what was transpiring. Richard replied that if I did not hear from him by 8:30 AM that the meeting was on. I felt confident that he would not back out of the meeting.

At 10:00 AM twenty-one labor representatives, men and women, congregated at the Alabama Labor Council for a briefing. At 11:00 AM, Richard Pizitz, his two brothers, father and sales manager greeted us. As we marched through his office door it looked like a wedding procession except the smiles on management's faces were strained smiles. Management realized quickly that this was not to be a brief, weak encounter with labor officials. Some of what transpired in the labor leaders conference and in the meeting with Pizitz is described in the following news letter sent out to all labor officials and certain other allies. These newsletters played a significant role in keeping labor officials informed, their interest up, and store executives scared:

Details of the January 16th Labor Leaders Conference

At last Wednesday's conference of labor leaders held at the RWDSU Hall in Birmingham, twenty internationals were represented with a total of seventy-one present. After the film showing, verbal presentation and discussion, those present unanimously agreed to actively support a Farah Slacks boycott campaign.

Following that decision, the different labor organizations broke down into groups by choosing which of the five Pizitz Department Stores their organization would assign volunteer pickets. It was decided also that as soon as possible the date and time should be set for consumer pickets to begin.

\* Note: We have learned that some labor leaders were not informed of the January 16th meeting because their names were not on our mailing lists. Since that meeting, we have tried to locate all labor leaders in order to update our mailing lists so that everyone can be kept abreast of boycott activities. If anyone knows of any labor leader who is not receiving these mailings but should be, please contact Jane Holcombe at the Alabama Labor Council (933-8956).

Details of the January 17th Meeting with Pizitz Management

Just prior to Wednesday night's conference, Pizitz management requested a meeting with labor representatives to discuss proposed boycott campaign activities. On Thursday morning, a meeting attended by 4 members of the Pizitz family, the stores' sales manager and labor leaders was held in Richard Pizitz's office. What transpired in that meeting follows:

Management spoke of their amazement, hurt and disappointment in learning of the proposed boycott activities when they felt they had been such good friends of labor for so long. Labor in turn used those same words of amazement, hurt and disappointment at the obvious fact that all of Pizitz Department Stores were continuing to make Farah slacks their #1 product in the men's department after labor leaders had been led to believe that Pizitz was cooperating with labor's legitimate concerns.

Pizitz mentioned that they had stopped all media advertising of Farah slacks. Labor representatives pointed out that even without media advertising, the fact remains that the majority of slacks stock piled on the shelves and racks of all Pizitz main level men's departments are Farah. If 6 or 8 of every 10 pairs of pants customers look at are Farah, then people are going to buy Farah whether or not they are advertised in the media. And since Pizitz is Alabama's largest department store and thousands of people shop there, then thousands of pairs of Farah slacks will be sold as long as they remain on Pizitz's counters.

Pizitz stated that they could not remove all Farah slacks from their shelves and cancel future Farah orders because they did not want to break their business relationship with Willie Farah who they emphasized is a very tough man (maybe they think he is tougher than labor). In other words, Pizitz tried to tell labor leaders that if the store were to dump Willie now, then Willie, once the strike were settled would no longer allow Pizitz to order and sell his quality slacks. Labor responded that this excuse did not make much sense because like any businessman, Willie Farah wants to make money. There is no way that Willie, assuming he does remain in business, is going to tell Alabama's largest department store and distributor of Farah slacks that he will no longer give them his slacks to sell. Labor is not so naive to be persuaded by this kind of thinking.



Union leaders emphasized that they were there representing the concerns of several thousand impoverished working people, people whose everyday lives were in a crisis situation and that they expected major concessions, emphasizing the phasing out of Farah products until the Farah strike is settled.

No agreements have as yet been made, however, Pizitz management did say they would make major concessions. Negotiations are continuing. Meanwhile boycott Farah campaign activities continue to be planned around the five Pizitz department stores.

#### Picketing Scheduled to Begin, Friday, February 15th

Consumer picketing at every entrance of the Pizitz chain in Jefferson County is scheduled to begin the 15th of February at 6:00 p.m. Picketing at every entrance of every store in the targeted chain will continue six days a week including all day Saturdays until Farah slacks are removed from retail shelves.

Labor unions must generate a picket drive with as much determination to maintain daily picketing quotas as civic organizations strive to meet their quotas in blood and United Fund drives.

If agreements have been made with Pizitz management in advance of February 15th, then all consumer informational boycott campaign activities will focus around Loveman's three department stores located in Westlake Mall, Western Hills Mall and downtown Birmingham. After agreements are made with Pizitz and Loveman's, the next targets such as Sokols and Jones-Lawless should come much easier.

Choose one of the following stores for your local to focus its picketing activities on. Then study the enclosed sample picketing chart and begin immediately to recruit as many volunteer pickets as possible for the period running Friday, February 15th through Saturday, March 2nd. Your local's efforts will be bolstered by pickets from other locals assigned to the same store.

#### Pizitz:

- (1) 1821 2nd Avenue North (Downtown)
- (2) Five Points West Shopping Center
- (3) 1917 2nd Avenue North - Bessemer
- (4) Eastwood Mall (Highway 78 East)
- (5) 9118 Parkway East - Roebuck

\* Note: If our target changes to Lovemans, for the most part, those locals assigned to Pizitz (1), (4) and (5) will be assigned to downtown Lovemans; those locals assigned to Pizitz (2) will be assigned to Lovemans in the Western Hills Mall and those locals assigned to Pizitz (3) will be assigned to Lovemans in the Westlake Mall.

All labor leaders including those who were unable to attend the January 16th conference will be contacted prior to the February 7th conference in order for the coordinating committee of boycott campaign committees to keep abreast of the progress being made. All labor leaders will also be immediately informed of any breaks in negotiations with department store management.

#### Next Labor Leader Conference Set For Thursday, February 7th

The next labor leader conference is scheduled for Thursday, February 7th at 7:30 p.m. at the RWDSU Hall, 1712 7th Ave. N., Birmingham. At that conference picket signs, boycott literature and instructions to pickets will be distributed. We will also have reports regarding the progress being made in building our picket line forces and community operated telephone-canvassing campaign.

The sample chart below is the type your local might want to use in its drive to sign up volunteer pickets. (We know that if each laborer does his/her part, no one will have to over-work themselves and the job will get done. After all, isn't that the union way - a lot of people working together in a concerted effort to get a job done?)

\* Note: All dept. stores are open Mon.-Fri. from 10 AM - 9 PM except the downtown stores. Pickets at the downtown stores will terminate on Saturdays at 4 PM. During the week pickets at the downtown stores will run from 11 AM - 2 PM in the afternoon and Mon. & Fri. from 6-8:30 PM and Tues, Wed. and Thurs. from 3:30 - 5:30 PM.

LOCAL 497 FARAH BOYCOTT PICKET SIGN-UP SHEET

DAY	DATE (FEB)	TIME	NAME & HOME PHONE #	STORE*	PICKET CAPT.*
Saturday	16	10:00 AM-1:00 PM	Joe Labor 436-5791	(2)	Sarah Broom
"	"	10:00 AM-1:00 PM	Pam Wins 777-4311	(2)	" "
"	"	1:00 PM-4:00 PM	Cecil Big 436-2217	(2)	" "
"	"	1:00 PM-4:00 PM	Betty Boycott 736-4410	(2)	" "
"	"	4:00 PM-7:00 PM		(2)	" "
"	"	4:00 PM-7:00 PM		(2)	" "
Monday	18	11:00 AM-2:00 PM		(2)	John Doe
"	"	11:00 AM-2:00 PM		(2)	" "
"	"	11:00 AM-2:00 PM		(2)	" "
"	"	6:00 PM-9:00 PM		(2)	" "
"	"	6:00 PM-9:00 PM		(2)	" "
"	"	6:00 PM-9:00 PM		(2)	" "
Tuesday	19				

\* (2) Pizitz (Five Points West Shopping Center)

\* Picket Captain's Responsibilities: The picket captain assigned for a certain day, will make sure that each person in his/her local receives printed picket instructions, boycott literature, and a picket sign with their local's name marked on it. (The ACWA organizer will distribute these materials to each local.) It is also the picket captain's job to make sure that their local's picket quota is met, that the pickets show up on time and that their local's picketing is coordinated with the picketing of other locals picketing the same store at the same time.

I think here it is important to discuss in a little more depth what took place in the meeting with Pizitz management. First of all, negotiations were being held. Both sides were conversing from positions of strength, yet already management's position of power was on the decline as was evidenced by the presence of 21 labor officials. After we all shook hands, finished introductions and got settled (there was standing room only) management immediately tried to put the labor forces on the defensive. Their strategy was to portray themselves as victims of a horrible conspiracy or misunderstanding when what they deserved was praise for their past cooperation and friendly relations with the labor community. This was a good strategy. For had they been able to convince any segment of my forces, like Howard Strevel for example, to their way of thinking, then my forces would have begun to splinter and my power base would then have begun to dissipate.

I knew when I chose Pizitz as the #1 target that the store chain, over the years, had pretty good relations with the labor community. Thus to be on the safe side, I continually reminded labor officails that Richard Pizitz, heir apparent to the business, was above all else a businessman and that whenever a conflict between friendship and the almighty dollar arose, Richard would always choose the almighty dollar unless forced to do otherwise. Just before and after <sup>the</sup> January 17th confrontation, I made it a point to get reiterations of commitments from each labor leader. It gave me a strong sense of security after the meeting when Howard Strevel responded "Just because Richard and I sit on community boards together doesn't mean that we are such close friends that I'll sell labor down the road. I'm in this to represent the interests of the Farah strikers."

Mike Pizitz began the meeting with a 15 minute introduction starting out with, "Frankly ladies and gentlemen the management of Pizitz was amazed, hurt and disappointed when it learned that a massive campaign was being mobilized to focus around our stores. Amazed, hurt and disappointed because we thought that those of you in the labor community were our friends. A friendship which we want to nurture and cultivate."

Mike then described Pizitz' history in its relationships with labor, highlighting examples of past cooperation and outward evidences of friendship.

As I sat and listened to Mike's propaganda, I could almost feel myself begin to question what right I had to confront Pizitz in such a threatening manner. However, this brief inner reaction did not make me lose sight of what I knew the facts to be. I knew from my several recent surveys of the huge quantity of Farah slacks on Pizitz shelves and the tremendous business his chain must be doing for the Farah Co. Yet I sensed that some of my forces might be mellowing inside towards the real confrontation we had come for. Therefore as soon as Mike was done, instead of waiting for someone in the group to respond, no longer had he uttered his last few words before I spoke. And this is what I began with, "Frankly gentlemen, to use your exact same words, those of us here representing the Farah strikers were amazed, hurt and disappointed to learn that Pizitz who we thought were such good friends of labor, are selling more scab Farah slacks than any other stores in the state...?" I gave percentages from my recent surveys, of the amounts of Farah slacks being sold in each Pizitz store. I knew that coming down hard like this would put Pizitz back on the defensive and if any of my backers were questioning their presence there, they were all soon brought back together.

Labor representatives kept emphasizing to Pizitz the seriousness of the issue. Richard, in an effort to discredit me, argued that my survey results were greatly distorted (To protect my credibility with labor officials and to solidify our position, Jim Freeman, Jack Baccari of the Communications Workers and myself made another survey of the amount of Farah slacks in Pizitz stores. This survey substantiated my earlier findings which we reported back to the labor officials). The meeting progressed as a nip and tuck struggle with labor proclaiming that all Farah was leaving town and Richard Pizitz holding his own and far from being totally beaten stood firm that under no circumstances was his store chain ever going to completely stop ordering Farah.

Richard's main argument was that to sever business relationships with Farah would put the Pizitz chain at a competitive disadvantage with its major competitors and would result in heavy financial losses. I in turn emphasized that we were not out to destroy anybody's business or to see anyone take heavy losses, however, I said, "Don't give us a sob story about your standing to lose so many thousands of dollars because that argument holds no weight with us. You've known of this situation for nearly two years. The fact that a multimillionaire may lose a few bucks is not our concern here. Our main concern are those several thousand impoverished strikers living on \$30.00 per week. And those are the people all of us who came here today are representing." I made one last strong affront to exhibit to my people the hideousness of the enemy. Near the end of our confrontation, I stood up and walked over to the desk where Pizitz father was sitting and as my voice rose and my fingers pounded on the desktop I said, "Men and women have given their lives on the battlefield for mankind and to protect persons rights like your own. All we are asking here today is for you to change some of your buying habits and to possibly lose a few dollars of profit to help several thousand impoverished people gain their rights and human dignity. And we are standing by our commitment that all Farah slacks are leaving this area."

The meeting ended after 1½ hours, with Richard still adamant that under no circumstances would Pizitz totally sever its business relationship with Farah but, realizing the seriousness of our visit, was willing to make major concessions if we were willing to negotiate on that basis. After the meeting I was assured by the laborites that whatever decisions I made from here on, they would back me up. I knew they were serious and believe me I appreciated it. These men and women were willing to stick their necks out all the way and I was not about to let them and the Farah strikers lose this one. I asked for suggestions from them. They suggested that I throw the ball back to Pizitz and find out what concessions they were willing to make at this stage of the game. "They know where we stand, now let's find out where they stand."

From this point on I knew that I could never let up on my supporters, targets or on opening new avenues of commitment.

I called Richard back and asked what concessions his store chain was willing to make. Richard seemed relieved that we were perhaps willing to come to some sort of compromise and promised that by early the next week his staff would draw up a list of concessions the store chain was willing to make. But he added, "At today's meeting, you got your message across to us. Please, at our next meeting, let us get together with just a few of your representatives." Before our conversation ended, I added a new dimension to Richard's worries. I said, "By the way Richard, as you well know, I have been meeting with numerous church and labor leaders as well as leaders of other community organizations. You also know from talking with me that I deal in specifics, that when discussing a subject, I like to know what it is I am talking about. Besides labor and church leaders, I have also been talking with leaders in the black community. One issue that seems to greatly concern them is your lack of hiring minority group employees, blacks in particular. Now Richard, if this is not the case, I certainly would like to inform these community leaders of such. In our meeting you made mention of a certain set of statistics revealing cuts or proposed cuts in your business relationships with Farah. You said then that if we promised not to pass the information on to anyone else that is contained in those statistics that you would reveal them to us. My response was that such statistics were of no interest to me. That I knew all I needed to know from my own survey of your stores which indicated that 60-85% of the men's slacks you stock are Farah. However, Richard, I would be interested in looking over your statistics pertaining to the number of blacks you have working in management positions as well as purely clerical positions." Richard, in response to my inquiry, after giving me a lengthy spiel on how the Pizitz chain was a leader since the Civil Rights Movement in providing job opportunities for blacks, stated, "However, under no circumstances do I give out such information as regards what the stores' hiring practices are." I in turn ended our conversation with, "That indicates something to me." I never missed an opportunity to build the real or psychological cam-

paign because either one or the other, I was confident, would keep labor's commitment that all Farah slacks were leaving Alabama.

What I had done while familiarizing myself with the targeted stores, surveying and diagraming them, was to notice the apparent lack of blacks working in the Pizitz chain. My observations were shared by blacks with whom I spoke. No such situation existed from my study of Loveman's stores which had an abundance of black employees. I also had learned in previous discussions with labor leaders that during the Civil Rights Movement the Pizitz chain had at times become a focal point of protest demonstrations. I felt that I had given Richard something else to have nightmares about that would help me in future negotiations. Not only was he seeing labor and church leaders coming after him, but now he saw the whole Civil Rights Movement possibly headed back to his doorstep.

In between our negotiating sessions, I continued to hammer away in newsletters, meetings and speaking engagements the issues of the campaign, the targets and the deadlines. There was no backing down from our stated position. Either Willie Farah and his cohorts were going to make fools of us all or else we were going to show Farah once and for all that his business was not welcome in Alabama. A designated committee of five labor representatives (R. B. Martin, UAW; C.T. Daniel, RWDSU; Thermon Coggins, USWA and BLC; Jim Freeman AFL-CIO; Ray Rogers, ACWA) met again on January 30th with Pizitz management to hear their suggestions of a compromise. Pizitz emphasized in this latest meeting that there was no way their store chain could sever ties with Farah completely. To do so would place their business at a tremendous competitive disadvantage with their major competitor who would still be stocking the area's most popular men's wear. However they listed five concessions they were prepared to make. The labor committee recognized the significance of these concessions but also realized that they were far from supporting labor's commitment that all Farah slacks were leaving Alabama.

From my earliest meetings with labor officials, I was acutely aware that there

was no love affair between themselves and Lovemans. And were a campaign set in motion, they were far more anxious to have its activities focus around Lovemans than around any other business. With this in mind, the labor committee decided to accept Pizitz offer, but not without the understanding of an added stipulation which I shall describe shortly. What had happened was that a situation arose which would allow the labor community to switch its focus over to the more savory target, the Loveman's chain, and in so doing would present the opportunity to "kill two birds with one stone." If Lovemans capitulated behind closed doors then Pizitz would have no argument at all to continue selling Farah and would have to follow suit or else blatantly ignore labors demands with no excuses to fall back on. If Lovemans happened to challenge labor, this would provide us with the confrontation we sought and against an enemy which was already looked upon with disdain by many leaders in the labor community. After we humiliated Lovemans and forced them to drop Farah, everyone else would have to do the same.

Richard returned my call to his home at 10:15 in the evening and apologized for my message not being relayed to him sooner. I told him that the labor committee would accept his offer. Richard was very pleased and assured me that his business would live up to its part of the bargain. He also began to mellow in his attitude towards me. He mentioned that in talking with the monsignor about <sup>ME</sup> ~~it~~, the monsignor told him that he would probably hate me for what I was doing but at the same time would admire me. Richard then added that, in all honesty, he actually had come to hold admiration for me and liked me. He hoped that sometime we could get together for dinner and exchange life's experiences. After a little pleasant and friendly conversation I added, "By the way Richard, I do want to add something to the understanding that we are coming to. As you will recall, you mentioned that the main reason you could not stop ordering Farah is because to do so would put you at a competitive disadvantage with your major competitor whom we both know is Lovemans. Well I just want you to know that your 90 day grace period is only good as long as Lovemans continues to order



Farah. But as soon as Lovemans stops ordering Farah, we are coming back to you and we will expect total cooperation from you whether that's one day, ten days or thirty days from now." This added stipulation was very upsetting to Richard and he responded, "But you can't do that. We have an agreement, 90 days after which we said we would get together again and make further significant reductions in our stock if necessary." [I knew, at this point, that if the boycott was not totally effective well within 90 days that it would not be effective at all. I was not about to drag the process out or let Pizitz off the hook in any way. Labor could not accept Pizitz concessions without the added stipulation otherwise we would be backing down from our original commitment that all Farah was leaving Alabama] I in turn responded that we had not yet come to an agreement and that we could not reach one until this stipulation became a part of it. Then I added, "Listen Richard whether you realize it or not labor has been darn good to you. Do you realize that labor in this area could take a hard nose stance and give you an ultimatum to remove Farah from your shelves and there wouldn't be much you could do about it except to go along or else face even heavier losses. Let's face it Richard, you have a very diverse business, a multi-million dollar business and you are not about to jeopardize your whole business in order to continue selling Farah Slacks regardless of the profits you derive from such sales. You should appreciate that the labor community is willing to come to some kind of understanding so that you won't have to suffer heavy losses." I then went over our understanding again and emphasized that according to the agreement, Pizitz could reorder a certain quantity of Farah slacks, but it would be doing so with the full knowledge of labor's commitment to clear the area of all Farah products, that labor leaders would be returning, and that his store chain could find itself with excess Farah slacks (about \$500,000 worth) which would have to be stocked in its warehouse if the Pizitz chain was not to become the focal point of Farah boycott activities. Richard replied, "Okay, I still hope we can get together for dinner sometime soon." At 11:15 that same night, Richard called me again at the Alabama Labor Council where Jane and

44

I were still working, to further question labor's added stipulation. I reiterated our position again and again we terminated our conversation on friendly terms, my point being made clear. The following newsletter describes the understanding which labor arrived at with Pizitz and indicates the change in boycott focus:

45

FARAH BOYCOTT ACTIVITIES #2

Labor Wins First Major Concessions With More to Come Soon

In the last report we failed to mention that it was 21 labor leaders representing 20 internationals who met with Pizitz management the morning of January 17th.

Agreements were made with Pizitz management on Wednesday January 30th by a special 5 member labor committee. The details of those agreements which are binding on the seven Pizitz Department Stores in Alabama are as follows:

- 1) Pizitz will stop selling all Farah slacks that do not have a Farah label (Farah is using many aliases such as Kainrod and Daire to fool the consumer).
- 2) Pizitz will not advertise Farah in any way. This means no media advertising whatsoever nor advertising within the stores such as signs, displays on special hangers or in windows, the dressing of mannikins, or salespeople urging consumers to the Farah counter.
- 3) Pizitz will sell Farah in only 2 departments instead of 5.
- 4) Pizitz will immediately cut their basic stock program by 50% and will allow authorized labor groups to check-out their stock rooms at any time.
- 5) Within 90 days Pizitz will cut their entire stock from its present 60-85% Farah down to less than 1/3 Farah. At the end of 90 days, Pizitz will then discuss further significant reductions.

THE LABOR COMMITTEE AGREED TO THESE CONCESSIONS BUT WITH THE UNDERSTANDING THAT ONCE LOVEMANS AGREES TO COOPERATE FULLY BY REMOVING FARAH FROM ITS SHELVES AND CANCELING FUTURE FARAH ORDERS UNTIL THE STRIKE IS SETTLED, THEN LABOR WOULD ALSO EXPECT FULL COOPERATION FROM PIZITZ. In other words, Pizitz 90 day grace period of not having to meet again with labor is only good as long as Lovemans continues to stock and reorder Farah. When Lovemans totally cooperates with labor, Pizitz will be expected to do the same.

If Pizitz decides to continue to reorder any Farah slacks at all which under the agreement it can do, then it is doing so with the full knowledge that labor has declared all Farah slacks are leaving the Birmingham area, that labor leaders are returning, and that Pizitz may soon find itself with excess Farah slacks which will have to be stocked in its warehouse if the Pizitz chain is not to become the focal point of Farah Boycott Campaign activities.

Important Negotiations: Lovemans President, Clifford Hoenke and Labor Leaders Meet

On Thursday, January 31st, Clifford Hoenke agreed to meet with a party of no more than two labor leaders. By the end of the 1½ hour meeting, Mr. Hoenke decided that the next step for him would be to call New York to talk with the Chairman of the Board and the President of the City Store Chain, of which Lovemans is a part, before making his final decision to cancel all future Farah orders and to remove whatever Farah slacks remain in Lovemans stores. It appeared to Ray Rogers, ACWA Organizer, and Jim Freeman, AFL-CIO Organizer, that Mr. Hoenke felt that it might reestablish good business relations between labor and Lovemans if Lovemans were to cooperate with labor's concerns at this time.

A Very Important Memorandum - The following is the text of a January 30th memorandum sent by Howard Strevel, Director, USWA District #36, to all staff members and local officers of the Steel Workers in the Greater Birmingham Area. A similar memorandum is also being sent out by leaders of Birmingham's 10 largest unions:

In a letter dated January 9, 1974, co-signed by myself and several other labor leaders, I made the commitment that to the fullest extent possible, the United Steel Workers of America District 36 would actively support a boycott campaign directed at removing all Farah slacks from the shelves of retailers in the Greater Birmingham Area.

I now want that commitment made in behalf of several thousand impoverished Farah strikers to be set in motion. I am thereby requesting with the utmost urgency that all staff members and officers of locals recruit the highest percentage of our membership as possible to join with other unions in picketing Lovemans Department stores according to a set timetable.

I am also requesting staff members and presidents of all locals to be present themselves or to send authorized representatives to the Thursday, February 7th conference of labor leaders scheduled at the RWDSU Hall, 1712 7th Avenue North, Birmingham at 7:30 P.M. At that conference, steel worker representatives should pick up picket signs, boycott literature, instructions to pickets and Farah picket campaign cards and should be ready to report the progress they have made in the recruitment of volunteer pickets.

Informational consumer picketing at all entrances of all Lovemans stores will begin Friday, February 15th at 6:00 P.M. and will continue indefinitely six days a week at the following locations and according to the following time shifts:

- 1) Lovemans - 216 19th St. N. (downtown Birmingham)  
 Monday & Friday - 11:00 A.M. - 2:00 P.M.; 6:00 - 8:30 P.M.  
 Tuesday, Wednesday & Thursday - 11:00 A.M. - 2:00 P.M.; 3:30 - 5:30 P.M.  
 Saturday - 10:00 A.M. - 1:00 P.M.; 1:00 P.M.-4:00 P.M.
- 2) Lovemans - Western Hills Mall and Lovemans Westlake Mall (Bessemer)  
 Monday through Friday - 11:00 A.M. - 2:00 P.M.; 6:00 - 9:00 P.M.  
 Saturday - 10:00 A.M. - 1:00 P.M.; 1:00 - 4:00 P.M.; 4:00 - 7:00 P.M.

Future Negotiations - Meetings with the executives of Jones-Lawless, Sokol's and Aland's will be requested for this coming week. All three of these stores are heavily stocked with Farah. They will be asked to cancel spring orders and to remove Farah slacks from their shelves or be subject to consumer Farah boycott activities.

Labor Leaders Conference Thursday, February 7th, RWDSU Hall, 1712 7th Ave. N., Birmingham at 7:30 P.M. - At this conference, besides picket signs, boycott literature, and instructions to pickets, several thousand Farah picket cards will be handed out for distribution to local membership. Each time a union member or a member of their family pickets, they should turn in a picket card to the president of their local.

Boycott Farah Slacks Being Sold Under These Labels: Golden Scroll, Classic 20's, Cliff Mark, Passport, Club 20, Beau Mark, Par Excellence, Farapress, Kainrod, Su Par, Knits, Daire, Slightly Irregular RN 21201, Lenox Royal, Kaufmann's, Macy's California and Time Out.

I should mention here that labor's original position was very hard line. Our intentions at first were that stores cancel all business relationships with Farah and shortly thereafter remove all Farah products from their shelves. We altered our position slightly when we realized that once a store had received shipments from Farah it was stuck with them as none could be returned. Since our objective was to hurt Farah in the pocketbook and not those stores which cooperated with us, we held the position that any cooperating store chain would be given ample time, but under close scrutiny, to rid of whatever slacks they had in stock provided they completely severed business ties with Farah. If it became necessary to focus a campaign around a business establishment, then the campaign would be continued indefinitely until all slacks were removed from the shelves thus the strong possibility of intense conflict and heavy financial losses. We found that the executives of each store we met with did not want bad publicity either by being the focus of an all out campaign nor by having it made public that they succumbed to labor's pressures. We let the executives know that as much as we could control the situation, we would not publicize the fact that any single business was giving up Farah. However, if we had to run a campaign around any business, the campaign would be so unique and effective that probably both the local and national news media would come in and do one helluva story and the business which was the center of attention was really going to lose face.

Businesses spend huge sums of money annually to promote a good public image. And it often takes years for a business to become well established with a name and reputation admired by all segments of the community. For this reason no merchant wants his business to become the target of intense controversy and all the bad publicity that goes with it since the image it took years to build could be destroyed overnight. The fear of mounting public controversy and all the bad publicity that a full scale campaign could start in motion was another selling point, in our psychological campaign, to force business executives to reach an early understanding with labor. I wanted no media coverage focused on any store preliminary to the full scale campaign as it

probably would not live up to the fears of anticipation building in the minds of store executives or, on the other hand, it might force merchants' backs up against the wall causing them to come out fighting and thus needlessly and more heatedly prolonging the conflict. A reaction from Richard Pizitz will serve as an indication of how sensitive retailers were to having the public learn about what was happening. In one of our final negotiating sessions, Richard produced a copy of the "Paperman," a six page paper which was the only media investigating the local boycott. He was quite upset that in the "Paperman" mention was made of the results of our negotiations. The labor committee suggested to Richard that he was becoming overly sensitive but nevertheless tried to reassure him that our negotiations would be kept as secret as possible. We would not however, base any agreements that we might reach on the premise that such information would not leak out. [Another reason for not trying to gain early media coverage from the major newspapers was that they advertised heavily for the store chains we were targeting. Thus our side could expect no adequate, in-depth or favorable coverage from the papers until the status of an actual full scale campaign were reached. In that case the newspapers and other news media would have to give adequate coverage of both sides of the conflict.]

The day after Richard and I concluded the agreement, I called Clifford Hoenke, the President of Lovemans. Mr. Hoenke could not understand why I wanted to meet with him as his store chain had, in the past, made its position clear regarding its continued sale of Farah. I was firm in stating that it would be in his best interests and that of his business to hear what I had to say but that the decision was up to him. He said that he would meet with me only, that he would not allow himself to be intimidated by a large group of labor people (this indicated to me that word had spread about 21 labor leaders walking in on Pizitz). I asked Mr. Hoenke why he would feel intimidated meeting with a group of labor officials. He responded by asking me how would I like to be converged upon by a crowd of businessmen. I said that I would welcome the opportunity to meet with any number of businessmen he could round up. That I would not be

concerned with numbers nor be intimidated by them. He stuck to his original position and I agreed to meet with him but called him back later at the suggestion of my New York office, and told him that I would have to have at least one other labor representative with me. He agreed to this and Jim Freeman and I met with him early Thursday morning, February 1st. Our meeting lasted 1 1/2 hours. Mr. Hoenke began by stating, "Look, philosophically you know where I stand and I know where you stand. Neither of us are about to change our philosophies. Therefore you do what you have to do and I will do what I have to do. I have plenty of money and would rather lose my job than take actions contrary to my philosophy in life. "Anyway," he added "Labor around here isn't united."

For about forty minutes Jim and I let Mr Hoenke do most of the talking. Then we signaled to one another that it was time to get down to business. I said, "Mr. Hoenke I want to tell you exactly what labor in this area is prepared to do. First of all, labor has made a commitment that all Farah slacks are leaving the Greater Birmingham Area. In fact they are going to leave the entire state of Alabama. Now we are going to describe in specific terms what labor is prepared to do if we can not come to an understanding." (Jim and I then described the entire campaign in minute detail) "Now you can call our bluff, perhaps we are prepared to carry on such a campaign and perhaps we are not. That's for you to decide. But I'll tell you right now, someone will find out come 6:00 PM. Friday, February 15th." Jim then made a few remarks and handed Mr. Hoenke a folder containing a memorandum from Howard Strelvel with diagrams of three of Lovemans' stores attached, a copy of the letter containing the signatures of ten labor officials, a description of what the campaign would entail, and a Farah sales analysis. Mr. Hoenke barely glanced at these materials and laid them aside. Now, becoming more defensive, he said that actually we could not do all that much that would bother him since we could only picket his downtown store and not his mall stores. And as far as the few pickets that had been distributing leaflets a couple days a week for the past couple of months at one entrance of his downtown

store, that was a big joke. Even the customers found it funny. Jim then assured him that those few pickets, although representing our interests, were in no way a part of what we were discussing today. And that he was mistaken to think that we could not picket his mall stores. Jim then stated that, according to the Logan-Valley Decision, we have every right to inform consumers of a struck product and that this right allows us to place pickets inside the malls at entrances into his stores. Mr. Hoenke then responded, "Well even if you can station pickets inside the malls, you can only put up a couple at any one time and that would have no effect. We again informed him that he was mistaken. We told him that we could put up 10,000 pickets if we wanted and it was all legal just so long as they kept moving and picketed in a peaceful and orderly manner. We added that we were prepared to continue picketing his stores starting at 6:00 PM. February 15th, 6 days a week indefinitely. We stated the specific peak shopping hours that each of his stores would be picketed. (Jim and I spoke and responded to all of his inquiries in an air of confidence and im precise, specific terms. Why? Because we were prepared before we confronted our targets. We were prepared and confident for two good reasons. Number one, we had researched our target and planned out carefully an effective campaign strategy and number two, we had mobilized the artillery to carry it out.)

Jim and I had to constantly assure Mr. Hoenke as we did other retailers that their business had not been singled out as the whipping boy. We were picking on no one business. The commitment was made by organized labor that all Farah products were leaving the state. We constantly reiterated that we did not want a confrontation but if necessary someone would learn the hard way come February 15th. Our constant theme in negotiations was that "we are not out to destroy anyone's business. The labor and the business communities need each other, but we, above all else, are representing the interests of several thousand impoverished strikers whose families are living on \$30.00 a week. It's both a labor as well as a moral issue with us. Why be loyal to Farah? He won't be able to fill your orders soon anyway. Either Farah



37

is going to treat his workers with the human dignity they deserve or else we are going to destroy Farah's business. We do not like to see businesses like your own go under because of Farah's obstinacy."

At all times Jim and I remained respectful and friendly but firm in our commitment, did not make direct threats but certainly implied ones, showed that we were genuinely concerned both for the strikers welfare as well as that of his business which we recognized was a highly successful and respected business in the community. One in fact where many union members shopped. We tactfully let Mr. Hoenke know that we recognized the right decision on his part not as a sign of weakness but instead an indication of smart business relations. "Above all else Mr. Hoenke we give you credit for being a smart businessman who knows when to make the right decision. If you weren't a smart businessman, you would not be as successful as you are now."

Mr. Hoenke began to more carefully examine the folder of materials which earlier he had glanced at and set aside. The following materials were contained in that folder:

- 1) The Howard Strevel Memorandum
- 2) Diagrams of Lovemans' Stores
- 3) Letter Signed by 10 Labor Officials (see page 16)
- 4) Campaign Description (see page 17, 18)
- 5) Volunteer sheet (see page 10)
- 6) Farah Sales Analysis



# United Steelworkers of America

District 36

SUITE 202 • 409 NORTH TWENTY-FIRST STREET

HOWARD STREVEL  
DIRECTOR

Birmingham, Alabama 35203

TELEPHONE  
322-8534



January 30, 1974

To: All Staff Members and Local Officers of United Steel Workers of America  
in the Greater Birmingham Area

From: Howard Strevell, Director

*Howard Strevell*

In a letter dated January 9, 1974, co-signed by myself and several other labor leaders, I made the commitment that to the fullest extent possible, the United Steel Workers of America District 36 would actively support a boycott campaign directed at removing all Farah slacks from the shelves of retailers in the Greater Birmingham Area.

I now want that commitment made in behalf of several thousand impoverished Farah strikers to be set in motion. I am thereby requesting with the utmost urgency that all staff members and officers of locals recruit the highest percentage of our membership as possible to join with other unions in picketing Lovemans Department stores according to a set timetable.

I am also requesting staff members and presidents of all locals to be present themselves or to send authorized representatives to the Thursday, February 7th conference of labor leaders scheduled at the RWDSU Hall, 1712 7th Avenue North, Birmingham at 7:30 P.M. At that conference, steel worker representatives should pick up picket signs, boycott literature, instructions to pickets and Farah picket campaign cards and should be ready to report the progress they have made in the recruitment of volunteer pickets.

Informational consumer picketing at all entrances of all Lovemans stores will begin Friday, February 15th at 6:00 P.M. and will continue indefinitely six days a week at the following locations and according to the following time shifts:

- 1) Lovemans - 216 19th St. N. (downtown Birmingham)  
Monday & Friday - 11:00 A.M. - 2:00 P.M.; 6:00 - 8:30 P.M.  
Tuesday, Wednesday & Thursday - 11:00 A.M. - 2:00 P.M.; 3:30 - 5:30 P.M.  
Saturday - 10:00 A.M. - 1:00 P.M.; 1:00 P.M. - 4:00 P.M.
- 2) Lovemans - Western Hills Mall and Lovemans Westlake Mall (Bessemer)  
Monday through Friday - 11:00 A.M. - 2:00 P.M.; 6:00 - 9:00 P.M.  
Saturday - 10:00 A.M. - 1:00 P.M.; 1:00 - 4:00 P.M.; 4:00 - 7:00 P.M.

# LOVEMAN'S

(6) 216 19th St N (downtown)

Open 10:00 - 8:30 Mon + Fri; 10:00 - 5:30 Tues, Wed, Thurs + Sat

24 Pickets

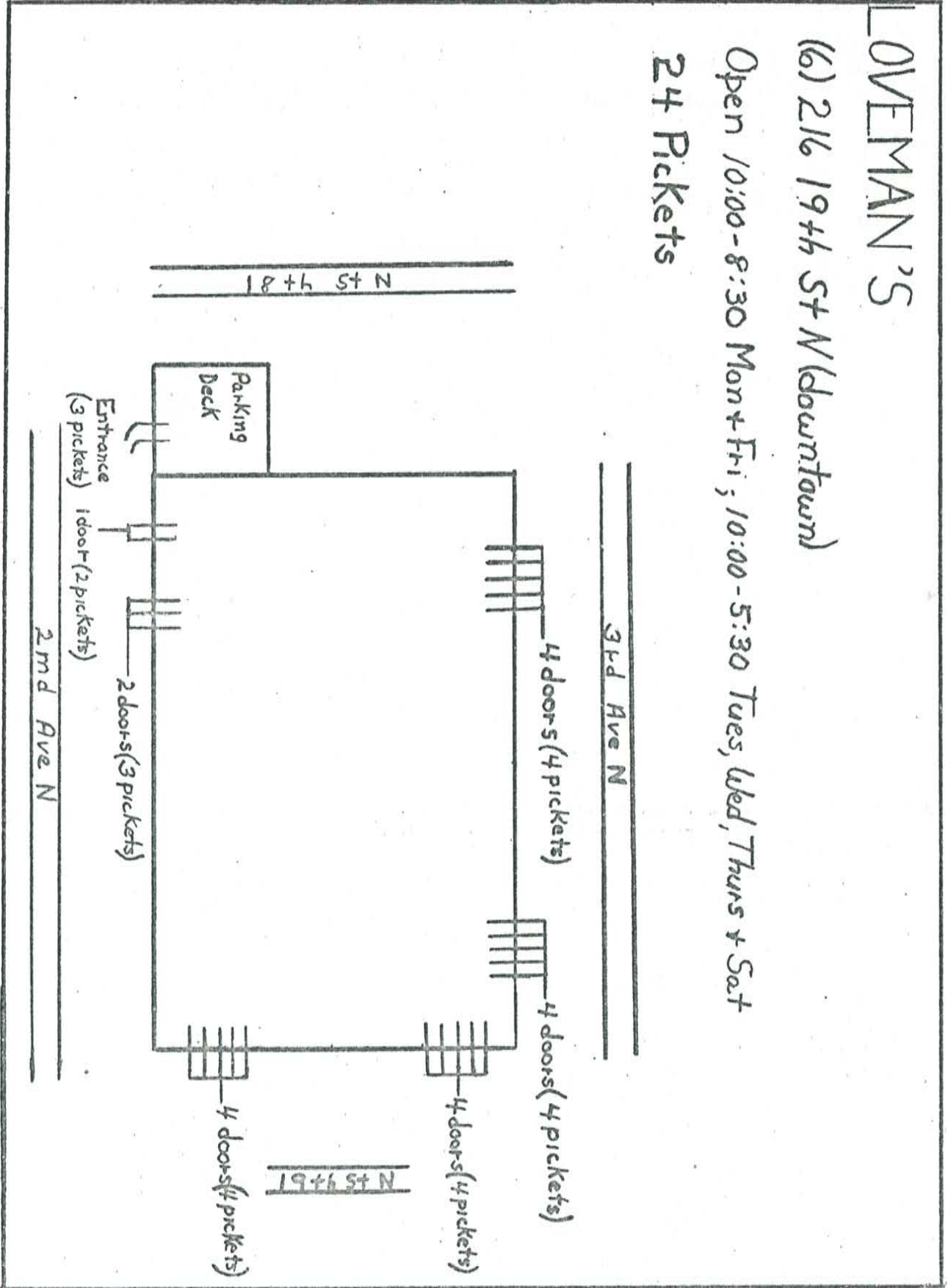

# LOVEMAN'S

(7) Western Hill's Mall

Open 10:00 a.m. - 9:00 p.m. Mon - Sat

24 Pickets

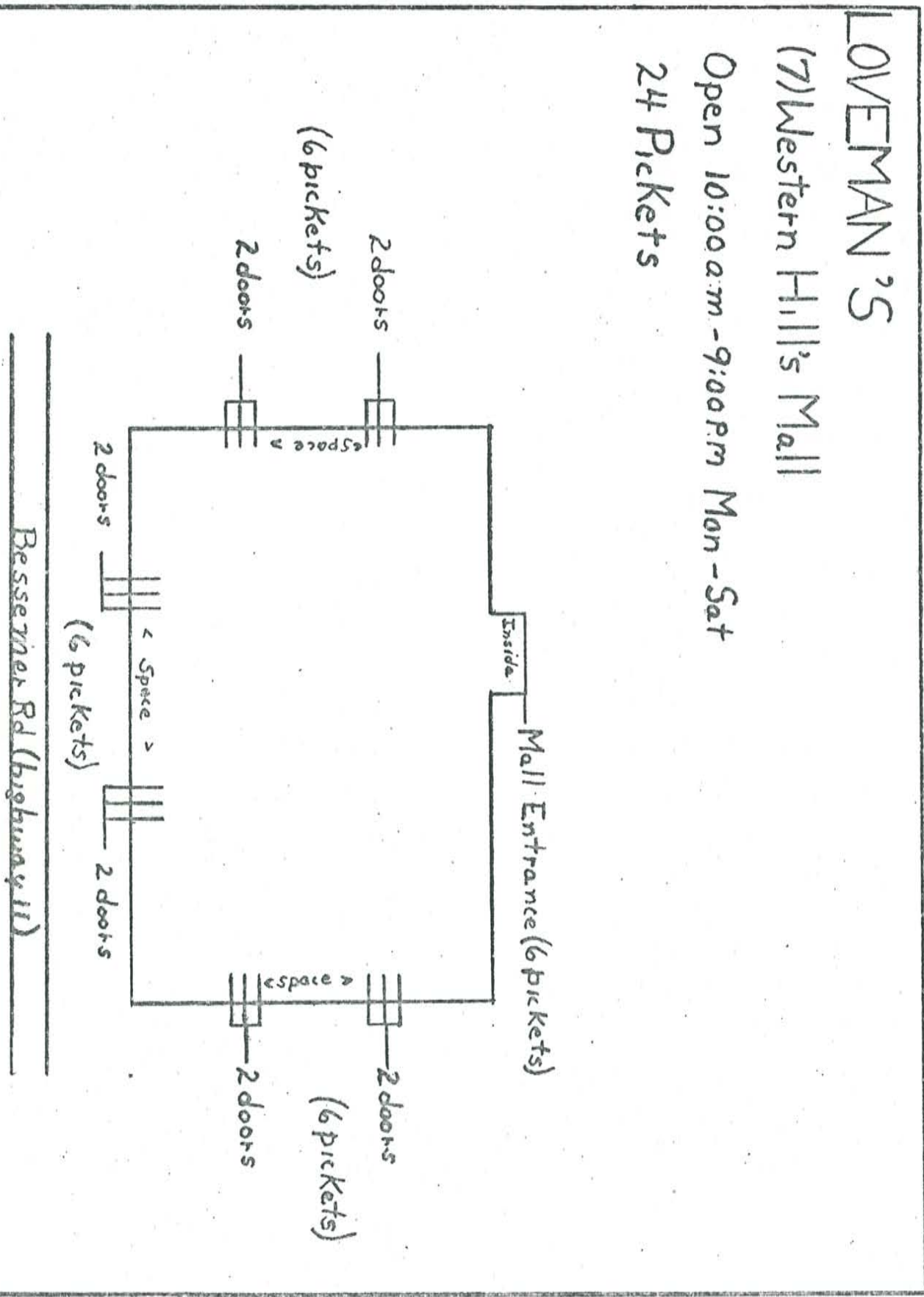

# LOVEMAN'S

(8) Westlake Mall - Bessemer

Open 10:00 a.m - 9:00 PM Mon - Sat

26 Pickets

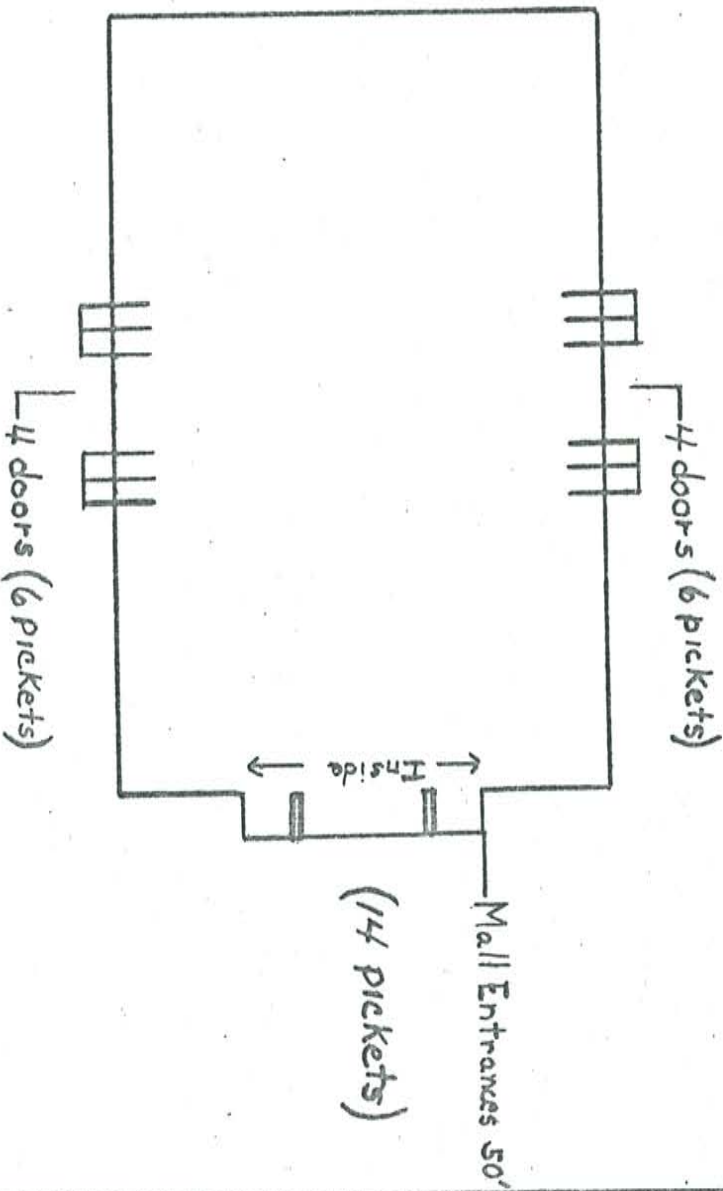

Bessemer Rd (highway 11)

# Don't let Farah's labor pains hurt you!

More and more, consumers are becoming aware of the injustices suffered by the Farah workers in their struggle for basic human rights: The right to join a union without having to face unmuzzled police dogs and Farah's armed guards; the right to live and work in dignity; the simple right to be recognized as human beings!

Hundreds of thousands of union members, civic, community and religious leaders throughout the nation have joined together to make the slogan, "DON'T BUY FARAH PANTS", a national moral issue. They're continually and effectively spreading the word about Farah's injustice through consumer picketing in the nation's shopping areas, and through consumer education programs in factories, churches, and schools all over America — the places where your customers shop, study, work and worship. Make no mistake about it — consumers are reacting with indignation and outrage against Farah's injustice, and with a determination not to buy Farah pants.

Stores which still carry Farah pants are risking a loss of Farah sales as that outrage is translated into "no sale" at the cash register. Even if Farah could deliver the goods on time next season, will consumers buy them?

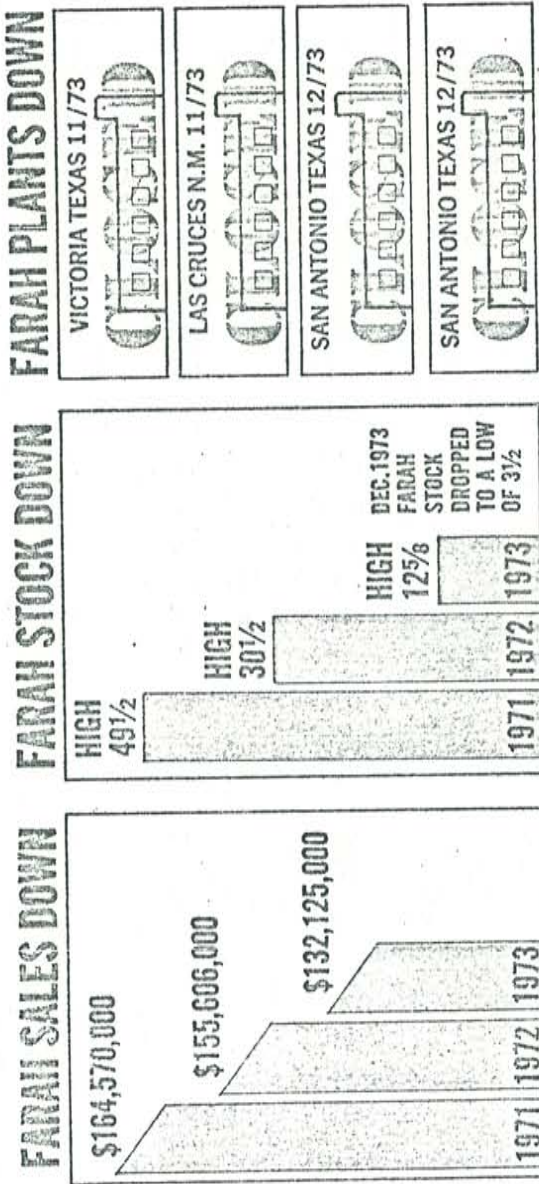

Wall St. Journal, Nov. 2, Dec. 7, & Dec. 16.

N.Y. Times Stock Report

Source: Farah Mfg. Co., Inc. Reports to Shareholders, 1971 & 1972 and Daily News Record, Dec. 20, 1973

**AMALGAMATED CLOTHING WORKERS OF AMERICA, AFL-CIO**

15 Union Square, New York, New York 10003  
 A UNION OF MASTER CRAFTSMEN IN:  
 MEN'S AND BOYS' SUITS/OVERCOATS/PAJAMAS/SHIRTS  
 LEISURE WEAR/SPORTSWEAR/OUTERWEAR/CHILDREN'S WEAR  
 WORK CLOTHES/UNIFORMS/NECKWEAR/GLOVES

710999  
 SERIES SDP

Mr. Hoenke's defenses all of a sudden dropped. He said that he would have to contact the chairman of the board in New York and would call us by early the next week with a decision. (Mr. Hoenke had gone from "You do your thing and I'll do mine, labor around here is not united" to "I've got to think of my business and be a good businessman. I'll call the chairman of the board and get back in touch with you.") As we were leaving his office, Jim and I made some friendly small talk with Mr. Hoenke and mentioned that the ill feelings felt by some labor officials towards Lovemans because of the treatment they had received from one of his subordinates months earlier, would certainly mellow and good relations between Lovemans and the labor community would be re-established if a satisfactory agreement regarding the Farah issue could be reached. We then thanked Mr. Hoenke for his time, honesty and the cordiality with which he received us.

For the next seven days, in a series of meetings, film showings, and speaking engagements, Jim and I hammered away at Lovemans which was now the #1 target. At the same time we described the predicament Pizitz was in. We also canvassed every store in the Greater Birmingham Area which did not sell Farah Slacks to inform store owners of what was happening and to warn them not to let other stores unload their headaches onto them. Jim and I felt that this sweeping action would prevent Farah salesmen from opening up any new accounts and would put additional pressure on store executives who might still have doubts as to whether or not labor meant to live up to its commitment. Preparation for the February 7th labor leaders conference progressed as we again made doubly sure that all labor officials were reminded of it. We were not too concerned however, over the possibility of a poor attendance at this second conference as labor officials themselves were calling the State Labor Council to make sure that they had the correct date and time for it.

During the seven days between the meeting with Mr. Hoenke on Thursday January 31st and his decision on Thursday February 7th, I telephoned executives of Jones-Lawless Men's Stores and Alands Department Stores, the #3 and #4 targets, to set up



meetings with them. On Monday or Tuesday the 4th or 5th, I spoke with Mr. Lawless, the Vice-President of Jones-Lawless. Mr. Lawless informed me that Mr. Jones, the President, was away on business, that he was just leaving to join him and that neither of them would return to Birmingham until the next week. He suggested that I call him back on Tuesday, February 12th to set up a meeting on that day. I did not say much to Mr. Lawless other than to indicate that it was very important for us to meet no later than Tuesday. He assured me that both he and Mr. Jones would be available for a meeting on that day.

Thus I went ahead preparing for the February 7th labor leaders conference and set up a system by which the focus of our campaign could be switched immediately from Lovemans to Jones-Lawless or to some other store chain should Lovemans or both Lovemans and Jones-Lawless reach an agreement with the labor community prior to the 15th. I know that the moment of truth was coming on or before the 15th. Either the psychological campaign would be a total or near total success by then or else the labor community would be set into a full scale campaign confrontation around a specific store chain. The impact of that campaign would have to be so devastating that our target would be forced to come to terms with labor and the example set would convince other store executives to do the same.

Jones-Lawless stores were exclusive men's stores loaded with Farah. Like Lovemans management, Mr Jones and Mr. Lawless had gained a reputation with many local labor officials as being anti-labor because of their refusal, in the past, to negotiate some sort of compromise regarding their heavy stocking of Farah. Jones-Lawless was #3 behind Pizitz and Lovemans on my "Big Three" list of businesses which were considered, by ACWA boycott coordinators in New York and by Alabama labor officials, as next to impossible to break.

As the February 7th conference neared, I figured that if Lovemans gave in to the psychological campaign then Jones-Lawless should become our next immediate target while the labor committee went back to renegotiate with Pizitz. Jones and Lawless

would then have to decide, with time running out and their backs against the wall, whether or not to call labor's bluff, something the larger and more powerful Lovemans did not dare to do. If they called our bluff then we would beat the hell out of their stores.

Using Jones-Lawless as our target for a full scale campaign would make the campaign alot simpler to coordinate since the picket recruitment would be reduced significantly from what we would have needed to sustain daily picket lines on either the Pizitz or Lovemans chain. In the meantime, Pizitz management and executives of other stores still doing business with Farah, would be warned to keep their eyes focused on the Jones-Lawless stores come 6:00PM. Friday, February 15th to see what we had in store for them after we finished with Jones-Lawless.

If Jones-Lawless gave-in to the psychological campaign, we would be ready to switch to Alands or Sokol's Department Stores, etc. immediately. If Jones-Lawless and everyone else gave-in without a fight then our #1 target Pizitz, which had already given-in part way and really had no defenses left, would be put into an impossible predicament. If Pizitz refused to submit to labor's demands in our scheduled meeting on the morning of February 15th, then labor would have set a new D-day 7 to 14 days hence. The campaign forces would have been increased and re-directed and Pizitz, I guarantee, would have been drubbed thoroughly.

Just before the February 7th conference I decided to implement a new system to recruit and coordinate our massive picketing forces. Earlier in the boycott, representatives of different union locals began to enlist volunteer pickets according to the system described in the first newsletter (see pages 34-5). The new system made it possible to break up picket recruitment responsibilities into small units which made it much easier to involve more people directly in the recruitment process without overburdening anyone. It also became more feasible to evaluate daily, the progress being made in recruiting pickets for each day, time and location weeks in advance. Thus I could know well beforehand who was failing in their job and for what days,

times and locations more pickets were needed. Based on this information, I could then fill the gaps and recruit accordingly in order to assure the overall success of the picketing program. This system also made contacting and following-up of volunteers and the whole procedure of switching picketing locations much less complicated.

The second labor leaders conference was just as successful as the first with representatives from nearly all the unions and largest locals attending. Picket signs and picket packets were there ready for distribution. Our picket signs were printed on both sides. On one side of one sign the name Lovemans was printed and on the opposite side Jones-Lawless. Other picket signs had Alands and Sokols printed on them.

Photos of Both Sides of a Picket Sign

Side A

Side B



If it became necessary to confront Lovemans with a full scale campaign, then while Lovemans was being picketed to death, word would spread throughout the community that Jones-Lawless would be hit next. This tactic would have an immediate psycho-

logical impact on Mr. Jones and Mr. Lawless and like the diagrams of each store chain, would really help send the message home to each retailer that anyone doing business with Farah would surely have their day as the #1 target on the firing line. If Lovemans happened to reach an understanding with labor and we were forced into a confrontation with Jones-Lawless, then when consumers or the news media inquired as to why we were hitting Jones-Lawless first and not Lovemans, we would inform them that Lovemans was cooperating with labor's concerns and we expected Jones-Lawless to do the same.

Picket packets were made up to cover picketing assignments for three weeks in advance. Emphasis was placed on recruiting pickets to fill all slots for each date, time and location at least two weeks in advance. Enough packets were made up so that twice as many pickets as the picketing plan called for would be recruited for each slot. Over recruiting 100% would assure picket coordinators that at least the number of pickets the plan called for would show up.

Each packet included a 7"X10" manilla envelope. Enclosed in each envelope were copies of instructions to pickets (exhibit A), diagrams of the Lovemans and Jones-Lawless stores designating the number of pickets needed at each entrance (exhibit B- see pages 53-55 for Lovemans diagrams), a picket-assignment, sign-up sheet designating a specific picketing assignment and containing spaces for six persons to sign-up to volunteer for that assignment (exhibit C) and picket campaign cards (exhibit D). The following are copies of exhibits A-D.

# NORTH ALABAMA AREA JOINT BOARD

*Amalgamated Clothing Workers of America*

220 43RD STREET, SOUTH

BIRMINGHAM, ALABAMA 35222

TELEPHONE 595-7886



## INSTRUCTIONS TO PICKETS (A)

In order to make this campaign successful, it will be necessary for you to follow these instructions carefully. You are not to attempt to take any other or different action than those specifically approved herein.

1. You are peacefully to patrol your assigned area at your appointed time. You must not engage in any loud talking, shouting, arguments or any other kind of misconduct. You are specifically forbidden from engaging in any physical attempt to block the entrance to the store you are picketing.
2. You are to picket only in that area designated by the union representative, which will be the consumer entrances to the store. You are not to picket at or near any entrances which are apparently reserved for use by the store employees and/or delivery men.
3. You are not to interfere with any employee of the store or any person making pickups or deliveries at the store. If any employee or delivery man should ask you what the purpose of the picketing is, you are to tell them that it is a consumer education picket line and that they should continue working in a normal fashion just as though it were not there. You should urge such employees or delivery men to continue working and indicate that they are free to cross the picket line. Other than as noted, you are not to talk to any employees or delivery men.
4. You must remember at all times that the Amalgamated has no dispute with the particular store that you are picketing. At no time are you to make any statement to the effect that the store is unfair to organized labor or on strike, nor are you to make any statement to anyone not to patronize the store. You may only request of consumers that they co-operate by refusing to purchase the particular apparel involved.
5. In the event that you receive leaflets or handbills to distribute, they should be offered to consumers courteously, without any attempt to force them to take any such leaflet. While the leaflets are being distributed, and especially at its termination, the immediate area should be cleared of those leaflets which the consumers throw away after receiving them.
6. If you receive any protest concerning your conduct from a public official or the manager of the store and you have complied with these instructions, tell them to notify the authorized union representative.
7. In the event any special problems develop while you are on your tour of duty, you are not to take individual action but rather you shall immediately notify the authorized union representative concerning the same. If you have any other questions concerning your activities, you shall also direct them to the authorized union representative.

# JONES-LAWLESS - Open Mon-Fri 10:00-9:00; Sat 10:00-6:00

(9) 9146 Parkway E - Roebuck - 12 Pickets

\*Wear House  
Is a Jones-Lawless  
owned store

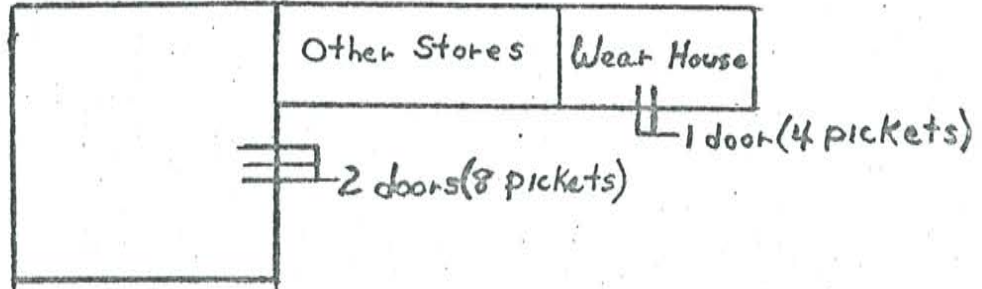

          
Parkway E  
        

(10) 7735 Eastwood Mall - 16 Pickets

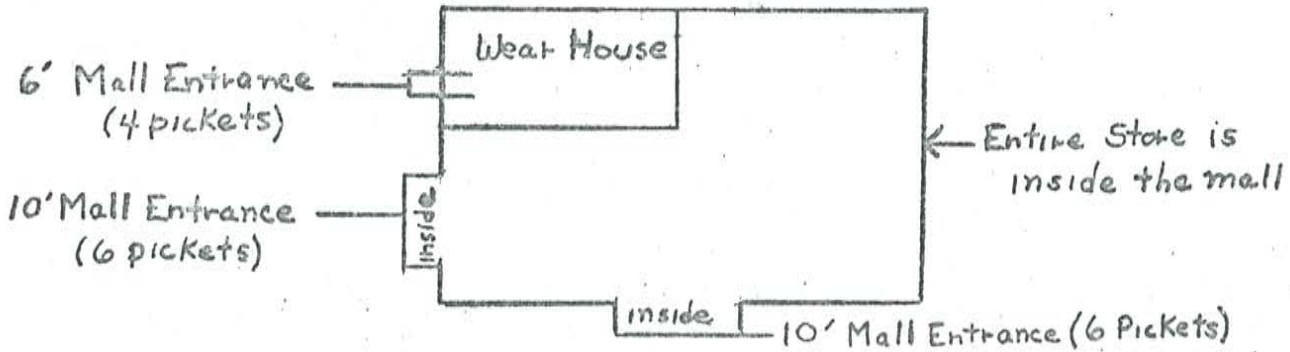

(11) Five Points West Shopping Center - 9 Pickets

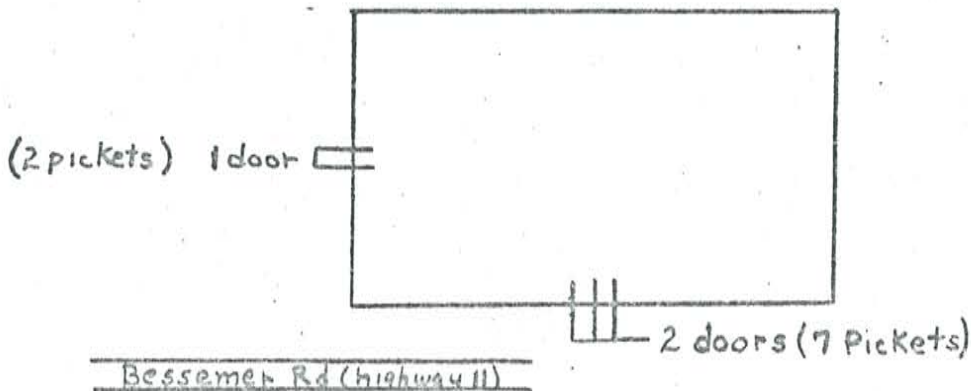

          
Bessemer Rd (highway 11)

A copy of the picket-assignment, sign-up sheet was stapled to the outside of each picket packet. All of the packets were then filed for each picketing location chronologically according to date and time. At the February 7th conferences, we set up tables designating each picketing location and then let union representatives select packets for those locations closest to where their family, friends and union members lived. For each picket packet a person took, they signed the copy of the picket-assignment, sign-up sheet stapled to the outside of the manilla envelope and turned it into one of the conference coordinators.

After the conference, Jim and I continued our heavy schedule of meetings and speaking engagements and kept distributing picket packets until we had them distributed for 2-3 weeks in advance. If after a couple of days someone who took a picket packet did not send in their list of six names to headquarters, then someone called them to check on their progress and if necessary started someone else recruiting pickets for those slots that were slow in being filled. As it turned out, by early the next week, after packets were distributed at the conference and the follow-up work done by Jim, Jane, myself and several others, we had so many pickets recruited to hit Jones-Lawless for the first couple of weeks that each of the Jones-Lawless stores could have been viewed as birthday cakes and the pickets as candles.

Each person who signed-up to volunteer to picket would receive a picket campaign card. This card would serve two purposes. First as a reminder to the volunteers as to where and when they were scheduled to picket, and secondly, after they did their job they were to turn in the card to the president of the local they represented so that they and their local could receive recognition for the support they gave the Farah picket line. It's surprising how a simple little card like the picket campaign card can help to develop interest and enthusiasm in a picketing drive. I had 30,000 printed up as a starter.

The central headquarters, with our new system, could check and follow-up on each person recruiting pickets. Also, once the list of volunteer pickets for a slot were

returned to headquarters, coordinators then had the necessary information to enable them to follow-up on and remind each person who had volunteered to picket. Thus it was possible to constantly evaluate the status of our picketing program for each date, days in advance and to hold persons accountable for the program's continued success.

At 10:30 on Wednesday February 6th, Mr Hoenke called the Alabama Labor Council and left a message for me that he would call back at 12:30. Then he called again at noon and left a message that he would be unable to call at 12:30 but would get in touch with me later. When I received Mr. Hoenke's second message I knew we had him on the run. I returned his call late that afternoon. He told me that he could not give me an answer right away, that he needed more time. "I'll be honest with you" he said. "I am looking into the legalities of what you propose to do and will stop you if I can." He mentioned that he was checking into some boycott work I had done in another city. I responded that he was mistaken, that I had never been to that city and that as far as I was concerned the boycott there was a sloppy one at best and I had nothing to do with it. Then I was very emphatic in stating, "Mr. Hoenke, when I organize a boycott, by God you'll know you've been hit by a boycott." Then <sup>he</sup> said, "I know you have contacted a number of religious leaders and don't think that they are all on your side. And don't ask me who the religious leaders are that I am talking about." I told Mr. Hoenke that I realized that all religious leaders did not agree with me on the Farah issue, but about 99% did. Furthermore, I did not care what religious leaders disagreed with my position, however I could probably come pretty close to guessing who he was referring to. I added that the director of the Baptist Youth Group didn't indicate any opposition to me, that the Episcopal bishop and myself had not yet had a chance to talk, that I knew he was not Jewish from our earlier meeting so I figured he was not in close contact with any of the rabbis and that I had the support of the three monsignors and the Catholic bishop with whom I'd met on several occasions. My guess was that a member of the Priest Senate, which I had addressed earlier in the day, who did not share my sentiments probably had contacted him. Then I added, "Listen Mr. Hoenke, I try to be very open and honest with you. I



have nothing to hide. Anything you want to know about my personal life, or work I've done in the past, just ask me. I'll describe both to you in specifics just like I told you specifically when our campaign would start and what it would entail." He then responded that I had been open with him and he appreciated my openness and frankness and my taking the time to warn him of what was taking place. He added that he would let me know his decision whether or not to terminate all business relationships with Farah by Monday. I said that was alright but that I had another big labor leaders conference coming up this week and the earlier we came to an understanding, the earlier I could change the focus of our campaign. He then said that he would let me know of his decision by Friday. I in turn informed him that the labor leaders conference would take place the next evening on Thursday. He told me he would try to give me his decision before the conference.

Meanwhile, that afternoon I called Ralph Aland, the president of three large Alands Department Stores. I introduced myself over the phone and, before I'd hardly said anything, Ralph broke in with, "Mr. Rogers I agree with you totally. I want those Farah Slacks off my shelves. You see, I lease my men's departments to Dave Levin of United Woolen Fabrics (itself a fine men's store laden with Farah). I am going to give Dave a call right now. You give him a call in about 15 minutes. I am sure that Dave will cooperate with you fully. Otherwise you call me back." (Ralph Aland obviously was aware of what was happening in the business community and wanted no part of it.). I knew I had Levin in a predicament of which there was no way out. He had to come to an understanding with labor on the Farah issue or else lose approximately 3/4 of his business as I could tell from Ralph Alands response that he was not about to have pickets and other boycott activities focused around his stores when he himself had no financial stake in Farah Slacks. Either Levin would cooperate or face the disastrous predicament of not being able to renew his leases.

I called Dave Levin but spoke to his wife who mentioned that Ralph Aland had just called but Dave was in New York on business. "Of course," she emphasized, "Dave will

want to cooperate fully, I don't normally give my husband's hotel number in New York to anyone, however since your business is of such urgency, I'll tell you where to contact him." I reached Dave late that night and discussed the situation with him. We agreed to meet Tuesday of the next week, February 12th, when he returned.

Mr.Hoenke called early Thursday to tell me that Lovemans' five stores in Alabama would no longer do business with the Farah Co. and that Farah would be informed of this decision immediately. (He was obviously shaken up by recent events and wanted no part of our campaign) I told him that the labor community did not want his business to suffer heavy financial losses and that we would give him ample time to rid Lovemans of the slacks it had in stock. I added that the labor community would appreciate his decision. He responded that if his decision was broadcast in the news media, that it had better be pointed out that under no circumstances did his philosophy or his viewpoint of the morality of the Farah-labor conflict change. That as far as his decision was concerned, it was purely an economic one made in the best interests of his business. He emphasized that if his position was not made clear, he would take out the biggest newspaper ad possible and refute everything said to the contrary. He felt the methods employed by me were as "immoral as hell." But when I interjected, "What about Farah putting his pants under 18 different labels to fool the consumer?" he responded, "Well you have a point there." He then added, "I don't know what good it will do to put pressure on Farah by getting us to cancel. After all we only do \$100,000 retail. Why don't you go after the big markets?" I reminded him of labor's commitment and that similar understandings would be reached with all other retailers or else he could see on February 15th who had not responded. "Well," he said "if you can get all the other retailers to do what I've done, I'll be willing to make the first statement in front of the cameras." I assured him that our progress was moving along well. "Chalk one up for your side," he said. "My side had better get moving."

No sooner had I put the phone down, than Jim and I were overcome with elation. We were like kids who had just seen Santa Claus for the first time. Immediately we

began removing Lovemans diagrams from the picket packets and crossing Lovemans name off the picket assignment sheet. That night at the conference we could announce the good news and zero in on Jones-Lawless which had just become our #1 target.

Up until this point, many persons in the labor community felt that a wide open confrontation with the business community was what the labor unions needed both to strengthen their unity and to convince the business community that labor's concerns had better be taken more seriously in the future. After Lovemans' capitulation however, it looked as though the boycott might be won without our campaign weapon ever being fired. The tremendous intimidation felt by the retailers would, alone, be enough to push them to their breaking point. This possibility, everyone began to recognize, was a much greater and unique accomplishment to strive for.

The next day on Friday, February 8th, I called Richard Pizitz. I said, "Richard we've got to get together soon. Lovemans is no longer ordering Farah." Richard in a choked tone responded, "They're not." We decided to meet the end of the next week on Friday morning of the 15th. I assured Richard that if Jones-Lawless did not come to a full understanding with us by that day that he and everyone else would be able to see the campaign in full swing starting that evening at 6:00 PM.

On Saturday night, February 9th, I happened to bump into Michael Pizitz and his wife going into the movies. We chatted in a very friendly manner. I asked him how it felt to buy tickets to the movie when, if he wanted to, he could buy the theater. He jokingly responded that by the time I got through with him he might not have the means to purchase a ticket let alone the theater.

Prior to Jim's and my meeting with Dave Levin and his wife on Tuesday, the 12th, I called the ACWA office in New York. Del Miliski, the national boycott coordinator, had an interesting story to relate to me. Someone who thought they had some pull with the national union office tried to intervene in Levin's behalf. Whoever tried to intervene said that Dave was having a lot of pressure put on him and requested that the forces in Birmingham be called off. The union informed whoever the intervener

was that the ACWA was involved in a full scale national boycott and under no circumstances would any boycott activities be called off.

That morning when Jim and I met with Dave and his wife, we reached a total understanding. Dave mentioned that his severing ties with Farah would really set his business back but that he understood fully the commitment made by labor and the predicament he was in. We told Dave that we knew it would hurt and that we were not out to destroy anybody's business, except of course, that of Farah unless conditions at his plants changed. Dave in turn made a statement that indicated to us that Willie was about to break and negotiate with the union.

Here was an instance where we had all of the power and management was in no position no matter how much it hurt to do anything other than to fully cooperate. Jim and I could have been arrogant bastards but we were polite, firm in our commitment, and at all times showed respect for our philosophical adversaries for what they are: hard working, respectable community members with highly respectable businesses. We realized that we had store executives in a terrible predicament and we tried to hurt their inner pride as little as possible. Willie, we knew, was receiving a constant stream of messages from Alabama and the impact of those messages was all that was important to us.

After the meeting with Levin, I called Mr. Lawless to set up a meeting for that afternoon. Mr. Lawless said that there was no way that either he or Mr. Jones could meet with us as they both were busy round the clock and would be leaving town the end of the week. I strongly suggested that both he and Mr. Jones, in the interests of their business, should find some time to hear what we had to say. Mr. Lawless was adamant in responding that a meeting at this time was not possible. My reply to him finally was, "Well let me tell you exactly what is going to happen starting at 6:00 PM. Friday and which will continue until you can find time to meet with labor representatives and come to some understanding with them." I followed this statement with specific details of the campaign. Mr Lawless kept asking why we were picking on his

stores. I kept reassuring him that his stores were not being singled out and that labor made a commitment to clear Farah Slacks out of the Greater Birmingham Area and the rest of the state and was going to keep that commitment. It just happened that Jones-Lawless was next on our list of priorities.

Mr. Lawless remained adamant in stating that there just was no time available for a meeting that week and that the earliest we could possibly get together would be on February 22nd. Finally I responded "Listen Mr. Lawless, don't you tell me that you can't find time to meet with labor. Labor representatives will meet with you any-time, anyplace, breakfast, lunch or dinner, 3, 4, 5, AM. in the morning, 24 hours a day. You just say where and when but don't tell me you can not find time. He responded, "Let's set a meeting a week from Friday. We will definitely meet with you then." I stated emphatically, "Mr. Lawless, if we don't come to some understanding by 6:00 PM. this Friday, I am going to be a hard man to find after that time."

As soon as the conversation ended, I called Jim and we immediately went to Mr. Lawless' office and waited for him. We greeted one another very cordially. Then, in a respectful manner, Jim and I told Mr. Lawless that we were concerned about his not being able to find time to meet with us, that we did not want to have to confront him with our campaign but unless we could come to an understanding by the end of the week, we had no choice. We emphasized the seriousness of the matter for all concerned and handed him a packet of materials to browse over similar to the type of packet that we handed to Lovemans' president Mr. Hoenke. Mr Lawless, very calmly and very courteously, still responded that he really did not have a grasp of the situation and that there just was no time to get into it. Jim and I of course knew he was stalling for time but we would have no part of it. If Jones-Lawless wanted to take us on by God, we were ready and after we got done with them all the other retailers would realize that we were not bluffing. The following newsletter was sent out that evening:

FARAH BOYCOTT ACTIVITIES #3 - February 13, 1974

Labor Gains Major Concessions

THESE STORES HAVE CANCELED ALL FUTURE FARAH ORDERS UNTIL THE STRIKE IS SETTLED:

Lovemans - 5 stores  
 Aland's - 3 stores  
 United Woolen Fabrics (United Men Stores)  
 Gateway Mall

The above stores, the next few months, will continue to sell the Farah slacks they have in stock. It is not the intention of organized labor that retailers should have to suffer heavy personal losses by dumping slacks in which they have invested heavily. Such actions would not hurt Willie Farah. Cancellations by retailers of all future Farah orders until the strike is settled will hurt Willie Farah. And that is organized labor's intention, to hurt Farah where it hurts the most - his own pocket book.

Special committees periodically will survey stores that have cancelled future Farah orders to assure that no new orders of Farah are being made,

Picketing of All Jones-Lawless Stores to Begin Friday, February 15th at 6:00 p.m.

Labor representatives have been trying these past two weeks to set a meeting time with Jones-Lawless management. Mr. Jones and Mr. Lawless claim that presently they are too busy to meet with labor representatives even though our representatives are willing to meet with them at their convenience anytime 24 hours a day.

A labor representative, in a phone conversation with Mr. Lawless on Tuesday, February 12th, described in depth the boycott activities which would center around the Jones-Lawless stores. That same day two labor representatives stopped by Mr. Lawless' office and left with him a folder of information relating to the boycott campaign. The next step is up to Jones and Lawless. Their decision to meet with or ignore organized labor will determine whether or not it will be necessary to focus Farah Boycott activities around their stores.

Informational consumer picketing at all entrances of all Jones-Lawless stores will begin Friday, February 15th at 6:00 P.M. and will continue indefinitely 6 days a week at each of the following locations:

- (9) 9146 Parkway East - Roebuck
- (10) 7735 Eastwood Mall (entire store is inside the mall)
- (11) Five Points West Shopping Center

according to the following time shifts:

Monday through Friday - 11:00 A.M. - 2:00 P.M. and 6:00 - 9:00 P.M.

Saturday - - - - - 10:00 A.M. - 1:00 P.M. and 1:00 - 4:00 P.M.

Please call Jane Holcombe at the Alabama Labor Council (933-8956) to obtain picket signs (we have 2,000 and can print more) and picket packets for the above locations and time shifts. A picket packet consists of a sign-up sheet with spaces for 6 names, 6 copies of instructions to pickets, a diagram of all Jones-Lawless stores designating the number of pickets necessary for each entrance and picket campaign cards. Each time a union member, a friend or a member of their family pickets, a picket campaign card should be turned in to the president of their local. Persons may also call the council to obtain one or more picket assignments and signs without taking a picket packet whether or not they are affiliated with a labor union

In its concerted effort to help thousands of destitute Farah strikers, the Greater Birmingham Labor Movement is on the brink of organizing one of the most successful boycotts in the history of this nation. Don't let up now, keep the boycott pressure on.

PIZITZ WILL BE ASKED FRIDAY TO CANCEL ALL FARAH ORDERS UNTIL THE STRIKE IS SETTLED.

We continued to mount a terrific force preparing all facets of our campaign to strike. I could not believe that any businessman who was convinced that we were prepared to carry on the type of campaign we described would be reckless or crazy enough to take us on. As the waiting game continued so did the speaking engagements and recruitment of volunteer pickets, telephoners, canvassers, etc. for many days in advance. Our campaign was ready to move in force and to build mightily with ever increasing pressure. For our pickets alone, we had recruited twice the actual number of volunteers for each time segment that we felt we needed to set up an effective picket line. For the Jones-Lawless stores, this numbered 148 pickets a day.

While we were building our forces and waiting on Jones-Lawless to give in, we were also contacting the next stores on our list of priorities and setting up meetings with their executives. Sokols was two department stores heavily stocked with Farah. I spoke to one of the three Sokol brothers on the phone and requested a meeting. He mentioned that I would want to meet with another person other than the store's owners. I said, "Mr. Sokol, you and your two brothers are the presidents of the stores, is that right?" "Yes" was his reply. "Then you are the ones who make the important policy decisions regarding your business. Is that correct?" Again he replied "Yes." "Well then you are the only ones who I will meet with." Jim and I knew that Sokols was in a horrible predicament because one of their stores was located in an area heavily populated with steelworkers and the other in an area which received a lot of business from mineworkers. If they lost steelworkers and mineworkers business, they probably would be out of business. Sokols with no hesitation whatsoever agreed to sever business relations with Farah.

On Thursday afternoon, February 14th I had a message to call Jones-Lawless. Mr Jones spoke with me and said that he and Mr. Lawless wanted to meet with labor representatives anytime and anyplace at our convenience. Did we want them to come to our office? I told him we had better make our meeting no later than 6:00 PM. so that if we came to an understanding, we would have at least 24 hours to call the

forces off. It wasn't long into our meeting that Mr Jones said he wanted no part of our campaign, that he had already been hurt by the bad publicity that his stores were selling scab pants. We had just beaten our last major obstacle. Jim and I knew the battle was won.

The next morning when the committee of five labor representatives walked into Pizitz's office, I knew that the power relationship between Pizitz and the unions had made a total reversal over what it had been years and months before. If I, with the backing of a few labor leaders, had asked for Pizitz's cooperation when I first arrived in Birmingham, I would have received none. For then, I was powerless to back up any sort of demands, implied threats or innuendos of such. Pizitz management was totally in the drivers seat. They had all the power, I had none at that time. On February 15th I had all the power and knew it. Pizitz had none and knew it. Labor was now doing the driving. We could have ordered Pizitz or any other businessman to put salt and pepper on their Farah pants and eat them and they wouldn't have had much choice but to do so or else face imminent disaster.

In the meeting, we laid the cards on the table. We let Richard know exactly what was expected of Pizitz. Richard hardly ever looked up from the floor. He was beaten and knew it. In his hand he had a couple of telegrams sent to him from the two big American Federation of Government Employee's Union locals which were dominant in the Huntsville area. We had already started building, within the AFGE, forces in the Huntsville area to deal with the Huntsville store. These telegrams were timed to reach Richard just before our meeting with him. Richard asked if we could take care of these telegrams and we said we would.

I believe Richard took the defeat very hard while others in his family and the management faced up to the reality. The struggle was over. It was a fact of life. So what, life goes on. The death blow to Pizitz business relationship with Farah was understood so keenly in our Friday morning meeting when, after we laid out our demands, Stets, the buyer for Pizitz men's departments remarked, "But what am I



going to do? I was having enough problems straightening out the men's departments with a 90 day grace period and heavy cuts in our orders. But what am I going to do now? I haven't even placed my Easter or Father's Day orders!" When he made this statement, Richard looked up at him and said "Stets, if you haven't made them by now, then you can just forget them."

These were the high points of our closed door negotiations with the managements of our biggest targets. Everything else was anti-climatic. However I should mention here that officers of the USWA and UMWA simply paid visits to three other stores and with the momentum of what was taking place around them, got these three large stores to sever business relations with Farah.

Ralph Reeves, a strong supporter from the steelworkers, summed up the campaign at our victory celebration on March 7th when he stood up, looked at me and proclaimed: "One thing is for sure. You can't call Birmingham, Scab City USA anymore."

The following are the last two newsletters sent out regarding the Farah Boycott in Alabama:

Labor Unity and Power At Work - Over One Million Dollars of Farah's Business In The Greater Birmingham Area Is Canceled

These stores will place no more Farah orders until the strike is settled:

Pizitz ----- 7 stores  
Loveman's ----- 5 stores  
Jones-Lawless & Wearhouse -- 5 stores  
Aland's ----- 3 stores  
Sokol's ----- 2 stores  
United Woolen Fabrics (United Men Stores)  
Gateway Mall

We repeat from our last Newsletter:

The above stores, the next few months, will continue to sell the Farah slacks they have in stock. It is not the intention of organized labor that retailers should have to suffer heavy personal losses by dumping slacks in which they have invested heavily. Such actions would not hurt Willie Farah. Cancellations by retailers of all future Farah orders until the strike is settled will hurt Willie Farah. And that is organized labor's intention, to hurt Farah where it hurts the most - his own pocket book.

Special committees periodically will survey the stores that have cancelled future Farah orders to assure that no new orders of Farah are being made.

The following stores will be asked not to do any future business with Farah until the strike is settled:

Yeildings  
Stag Shop  
Cambridge Men's Shop  
Sir Pants-A-Lot  
Paul's Clothing for Men  
Goldstein & Cohan  
Blach's  
Greenhall's  
Terry Town

Please contact Jane Holcombe at the Alabama Labor Council (933-8956) if you are aware of other stores selling Farah Slacks in the Greater Birmingham Area that are not listed in this newsletter.

LIKE THE FARAH STRIKERS; THE GREATER BIRMINGHAM LABOR MOVEMENT CANNOT BE BEATEN!!!

FARAH BOYCOTT ACTIVITIES #5, February 28, 1974

Why the Sudden End to the Farah Boycott?

For some time, articles have appeared in newspapers and magazines pertaining to the labor-management struggle between the Farah Slacks Manufacturing Company and several thousand impoverished Chicano employees seeking union recognition. Those following this struggle might be under the impression that the reason for Willie Farah's sudden recognition of the workers' grievances resulted from the recent NLRB decision which appeared in the January 29th edition of the Wall Street Journal. Certainly this decision did not strengthen Farah's position. However, what the public should realize is that Farah, according to published newspaper reports and reports from Amalgamated Clothing Workers Union officials, planned to continue fighting unionization efforts by appealing the NLRB ruling through the lengthy court appeals process.

The New York Daily News Record on February 25th wrote, "Farah wouldn't answer questions about the losses his firm has had, nor would he respond to queries of why the dispute has come to a sudden end...He added that the boycott of Farah products had had a very vicious effect."

So far, what the general public and the rest of organized labor throughout the nation does not realize, but should be made aware of, is the tremendous impact that organized labor in the Greater Birmingham Area had on forcing Farah to the negotiating table to bargain in good faith. In fact the heavy pressures that labor organizations exerted in recent weeks on Alabama's biggest retailers, resulted in what is one of the quickest and most effective urban boycotts in labor history. What took place in the Greater Birmingham Area exhibited the power that organized labor in the South and particularly in Alabama has to influence national labor concerns.

Someone In Birmingham Is Knocking The Hell Out Of My Business

According to ACWA officials, Willie Farah himself, during negotiations in Texas commented to the effect that someone in Birmingham is "knocking the hell out of my business." This statement and Farah's sudden capitulation can be more clearly understood when one considers what took place in Alabama between February 7th and 18th--nearly two million dollars worth of Farah's business was cancelled.

See Excellent Newspaper Summary of the Alabama Farah Boycott Campaign in the issue of The Paperman for the week ending 7 March 1974. The Paperman is published each Wednesday by The Paperman Publishing Company, 929 South 22nd St., Birmingham, Ala. 35205, H. Randall Williams, Editor, 322-1818.

What is so noteworthy about the Farah Boycott Campaign in Alabama is: first that it was so effective and secondly that it was conducted in such a way that, even after the battle was over, opposing forces walked away with mutual respect and admiration for one another. In effect, after all was said and done, relations between retailers and labor are such that either may enter the others place and not feel they have just entered the lion's den.

\*\*\* In appreciation for the great accomplishment in Alabama the Amalgamated Clothing Workers of America invite you and other friends of the Farah Strikers to a VICTORY CELEBRATION - Food and Beverage Buffet Style: \*\*\*

Place: RWDSU Hall, 1712 7th Ave. N., B'ham  
Date: Friday, March 8th  
Time: 7:00 P.M.

Appendix I - The Role Played by Elements of the Religious Community

Prior to being sent to Alabama, I remembered reading about a progressive group of Alabama clergy called the Greater Birmingham Ministries. I made it a point to contact them early and on December 19th met with the group's two most liberal and pro-union members, Reverends Bill Chilton and George Quiggle. These two men were staunch allies and very sympathetic to my reasons for being in Alabama. They gave me insights into the religious community including confirmation to my growing awareness that I should expect little active support from any but a handful of religious leaders. They also suggested whom to contact in the Catholic clergy. Following their advice, I contacted Monsignor Foster and through him a meeting was set up with the local bishop, Bishop Vath.

Catholics represented a very small percentage of organized religion in the Birmingham area but because I was aware that the Bishop in Mobile, Alabama had, in the past, given his blessings to the success of the nationwide boycott and because of the strong stand taken by Catholic bishops across the country in behalf of the Farah strikers, I looked to the Catholic clergy to help generate much of the religious support I initially sought. I had planned to have one clergyman or clergywoman scheduled to walk the picket line at each targeted store with the labor forces. However I learned early not to count too heavily on such support as there apparently were few clergy in the Birmingham area who would not frown upon such activity. Nevertheless, I set out to gain as much support as possible from the religious community.

I first met with Monsignor Foster on December 20th and afterwards with Bishop Vath. I indicated to Monsignor Foster my concerns and my commitment. I outlined my strategy, relayed to him that Pizitz would probably be my #1 target and I also let him know that I planned on striking my targeted store chain with little or no warning since these businesses had ignored the strikers' concerns for nearly two years. It was obvious to me that Monsignor Foster realized the seriousness of my

presence in Birmingham, however I was unaware at this time that he and Richard Pizitz were close friends. With Bishop Vath I spent nearly an hour covering everything that I had just covered with Monsignor Foster. Bishop Vath surprised me with his openness and frankness and the insights he relayed to me. I knew I had a strong ally in him. At the end of our conversation he warned me that certain elements in the community would set out to destroy me in whatever manner necessary if I began to accomplish what I'd set out to do.

I spent from December 28th through January 1st at home in Massachusetts for the New Year's holiday. After my return, I telephoned Monsignor Foster to schedule a meeting to discuss what procedures I should take to inform the Catholic community of the Farah boycott and to mobilize much greater support from it. In our conversation, Monsignor Foster mentioned that he had tried to reach me over the holiday to invite me to a gathering at his house. He said that Richard Pizitz and other close friends of he and Richard had gotten together for a holiday celebration. He wished that I could have been there as he felt sure that if Richard and I had the opportunity to meet informally I would find out what a really fine person Richard was and that matters concerning Richard and I could then be worked out easily and quietly. This was the first indication that I had that Monsignor Foster and Richard Pizitz were close friends and anything I mentioned to Monsignor Foster probably would find its way back to Richard. Monsignor Foster found himself in kind of a dilemma. He was genuinely concerned over the plight of the Farah strikers but was equally disturbed over what might happen to the Pizitz family and their business in the weeks ahead. For these reasons, I believe Monsignor Foster was trying hard to make Richard realize the seriousness of my presence in Birmingham to help him avoid the massive campaign confrontation that was brewing. In my January 8th meeting with Monsignor Foster, he came on very strongly in suggesting that I contact Richard to try and settle our differences. He felt at this time that Richard and I would have little difficulty reaching an agreement since Richard now viewed the Farah issue differ-

ently. I told the Monsignor that I wanted to stick to my original strategy of first building a strong base of support so that when Richard and I did meet it would be on equal footing where he would know that I was not bluffing and thus would have to listen to me in the interests of his business. The Monsignor questioned the morality in my willingness to set out to destroy a man's business without making every effort ahead of time to come to some type of settlement. He questioned my belief in the workings of Jesus Christ and the Holy Spirit. He asked me to give the Holy Spirit a chance to work on Richard. I responded that I did not question his remarks that Richard Pizitz was a fine family man and an asset to his community. I reiterated, however, my feeling that Richard's main interest in the Farah issue was strictly the profitability of his continued relationship with the company and that trying to negotiate with him before solidifying my power base and mobilizing campaign forces would serve no useful purpose. The question of ethics would not impress him. I added that I believed in the workings of the Holy Spirit but I also believed that there were times when the Holy Spirit could use some help. Monsignor Foster persisted in urging me to contact Richard indicating that Richard would be very receptive to meeting with me. Finally I began to feel that the Monsignor knew more than he was letting on and that Richard already was eager to settle our differences only he did not want to lose face by contacting me initially. Thus I told the Monsignor that because of my respect for him and his opinions, I would contact Richard before the threat of a full-scale campaign confrontation hovered over him.

Then I had a lengthy discussion with Bishop Vath. I described to him what had transpired in my meeting with Monsignor Foster. Bishop Vath quickly brought me back to my original strategy of letting Richard make the first move. He told me that he attended a Christmas party at Monsignor Foster's house. No sooner had he set his foot in the door than he was led into a room to meet Richard Pizitz and my presence in Birmingham became the topic of conversation. The Bishop felt that Richard was strongly committed to sticking with Farah and that I should stay with my original

strategy of building my power base and confronting Richard only when I knew that a significant amount of power had shifted in my favor.

That night I called Monsignor Foster and told him I had decided not to contact Richard after all because of information I'd received since meeting with him which indicated to me that Richard was committed to staying with Farah and thus any meeting between us at this time would be fruitless. The Monsignor understood my position and indicated to me that he did not want to get in the middle of the apparent struggle that was brewing.

From the constant feedback received from various segments of the community, Richard became keenly aware that a professional trouble shooter was in Birmingham representing the interests of the Farah strikers. He knew sooner or later that he would have to confront this person and deal with <sup>him</sup> cautiously. The mounting support from various segments of the Catholic community and the direct warnings Richard was receiving from Monsignor Foster, I am sure, intensified the psychological campaign adding considerable fuel to Richard's growing apprehensions prior to his decision to contact me through a labor official.

At Christmas time Reverend Quiggle sent a letter to twenty clergy members, some of whom he felt might want to become actively involved in the boycott. Not too long after his letter was sent out, Reverend Quiggle was contacted by Farah representatives who wanted to meet with him to explain their version of what was happening at Farah's plants. Reverend Quiggle informed me of this and sought my advice before agreeing to meet with them. What Farah had done was to send two Chicanos up from Texas. These men and two of Farah's representatives in Alabama tried to serve as a public relations team meeting with various religious leaders, and perhaps others of whom I was not aware, to persuade them not to support the boycott. Their efforts failed and whatever report they sent back to Farah was not good.

Besides those mentioned, I was in contact with other leaders in the religious community whom I feel would have eventually played important roles in the boycott had it not been so successful so quickly.

Appendix II - Building and Sustaining a Power Base

One advantage which helped me to move more quickly in building my power base was that labor officials were already aware of the labor-management conflict existing at the Farah plants. For nearly two years they had been receiving periodic newsletters from the AFL-CIO regarding the Farah strike and boycott. With this in mind and based on the success of the Alabama boycott, the following should serve as an outline of steps that might be adapted by organizers to build and sustain a labor or other particular power base:

1) Start contacting every labor official in person beginning with the most powerful and influential. Measure their response to the issues at hand and their willingness to have members of their organization play a supportive role in deciding the outcome of the conflict.

2) Set up a full schedule of speaking engagements, running 7 days a week, at union meetings. Communicate the issues involved, the type of campaign you visualize as necessary to defeat your adversaries, and the commitment of both yourself and the primary organization backing you to see this campaign through to the end.

3) Everywhere you speak, distribute sign-up sheets for volunteers(see page 10), By doing this, you will begin to record a potentially large force of volunteers, some of whose skills you will want to make use of ~~enlist~~ immediately and others who can be called upon to support a full-scale campaign effort if such becomes necessary.

4) Once you feel that you have (a) gained a commitment from the majority of the area's most influential labor leaders to lend whatever support their time and position will allow, and (b) that the rank and file can be turned on to the issues at hand, you should plan the best time within the next couple of weeks to hold a labor leaders" conference and then set the wheels in motion to organize such a conference.

5) To draw labor leaders or their top representatives into such a conference:

(a) Have the president of the local labor council agree to send a letter to officials of all labor organizations in the area, both affiliates and non-affiliates



of the AFL-CIO. This letter should remind labor officials of the seriousness of the issue at hand and should inform them of the conference and the importance that they themselves or a high ranking representative of their organization attend. Prepare the letter yourself and tell the president that this is how you thought it might sound. Chances are, the president will accept it the way it is or alter it very little. Have the letter printed neatly and professionally on his letterhead and mailed out first class postage (see Thermon Coggins letter, page 14 ).

(b) Prepare another letter which stresses the significance of the issue, the commitments made by the most powerful labor leaders, and the importance that high-ranking representatives from every labor organization attend the conference. Have this letter signed by a number of powerful and respected labor leaders and attach such materials as you deem necessary to help communicate to every labor official that something big is happening that has a high degree of professionalism and commitment behind it and which their organization had better be in on (see letter and attachments, pages 16-24 ).

(c) Follow these letters with two phone calls, the first approximately 3-4 days prior to the conference, the second the day of the conference (study telephone messages and evaluation form, pages 27-29 ).

(d) From the time the first letter reaches mailboxes to the night of the conference, the organizer should do continuous follow-up by personally visiting as many labor officials as possible and stressing to them that the support of their organization is essential if the campaign is to succeed and labor in that area is to exert its influence and win a major victory.

(e) If you have a real labor issue and have done your homework properly, the conference will be well attended. Just make sure that it is run in a well organized and professional manner, that the agenda deals with specifics and that a sense of direction of where and how we go from here results from it. If the conference comes off well, you have the foundation of a strong power base.

6) During the labor leaders' conference, the organizer should have some indication for the amount of active support being generated. Perhaps a date can then be set for D-Day, the beginning of a full scale campaign against a specific target. Labor organizations can then be broken down into groups and assigned specific responsibilities according to a series of timetables.

7) Plan perhaps one more labor leaders' conference two to three weeks after the first and one to two weeks prior to D-Day so that progress can be evaluated and the organization kept in tact. Based on progress reports, a great deal can be accomplished at this second meeting and in days ahead to assure that the campaign is on a collision course.

8) Continually keep all labor officials and other interested parties informed of the boycott's progress through a periodic newsletter (see five newsletters, pages 34-36, 45-46, 72, 76, 77). Never let the most influential labor officials go too long without a personal visit and make periodic telephone calls to other officials to keep them abreast of what's been taking place behind the scenes.

9) Keep up constant activity, keep reaching out to more and more people. Constant contact, follow-up and evaluation with respect to every facet of building and running the campaign never stops until it is won. Such constant and widespread activity helps to build and strengthen your organization by enlisting new supporters and by acting as a reinforcing agent to persons already active in boycott activities. It also gives your adversaries the impression of being up against an organization of much larger proportions than may actually exist. This of course creates a tremendous psychological advantages which can be valuable during negotiations for as someone once observed, 'if you have 100 soldiers but your enemy thinks you have 1000 soldiers, then you can negotiate from the position of strength of having 1000 soldiers.'

\*Any organizer who can build the type of power base and campaign I have been describing probably would never have to set the full-scale campaign in motion. There is

a principle of power relationships that states "that the threat of a tactic is usually more terrifying than the tactic itself but only if you are so organized that your opponent knows not only that you have the power to execute the tactic but that you definitely will." The campaign might violate this principle to some degree. It may be more terrifying in actual operation to a business establishment than even its executives could imagine. One thing you can bet on. If business executives really believe that you are prepared to focus a full-scale campaign around them, they, like the retailers in Alabama, will capitulate out of fear of what the repercussions might be and your campaign will never have to be set in motion. However should anyone ever doubt your power and call your bluff, be prepared to annihilate that target so that no one will ever call your bluff again.

Appendix III - Notes on the Preparation and Type of Telephone, and Door to Door Canvassing Operations Which Would Have Been Employed in the Alabama Farah Boycott if Necessary

To understand the telephone and canvassing operations, which would have been employed to create immediate boycott pressures and the greatest immediate psychological impact possible on the targeted retailers, one must be familiar with the different sections of city directories (also referred to as criss-cross directories). Three sections of the Birmingham area directories would have been particularly useful. They are the alphabetical directory section, the street directory section and the telephone directory section.

The alphabetical section lists businesses and private residents. Under the listing of a person, besides the address, the occupation of the person is usually indicated. Thus you might discover that Laurette Caldwell lives at 127 15th Street and is the bookkeeper at one of Pizitz's department stores. By perusing the alphabetical<sup>section</sup>, one could make a list of the names and addresses of practically all employees and management personnel associated with a particular store. Such a list is important if one is to develop the type of high-impact psychological campaign strategy I will describe shortly.

The street section lists in alphabetical and numerical sequence all streets. Under each street name, dwellings are listed in numerical order. The following information is furnished for each dwelling: the occupants and oftentimes their occupations, telephone number and zip code.

The telephone section is a complete list of all telephone numbers numerically listed under appropriate exchanges and with the owner's name. For example, every phone number in a city which begins with the digits 256 will be listed together in numerical sequence with each telephone owner's name.

Now I will describe how the city directory would assist me in targeting the telephone and canvassing operations (canvassing operations include door to door leafletting and door to door house calls). Remember, Alabama retailers were made aware

of every facet of the campaign that would be employed, if necessary, to inform the public of the boycott. Besides the picketing and continued public relations work focusing community discontent on their businesses, retailers also faced the threat of being confronted with a massive telephone and canvassing operation. This concern compounded their fears. Such a multi-faceted campaign, they sensed, would assuredly do irreparable injury throughout the community to their business's image and reputation.

If any business executives happened to call labor's bluff, I wanted a campaign that would communicate our message so fast and so convincingly that they would capitulate practically overnight, realizing fully that labor meant to carry out its commitment. To convince retailers of the enormity and overpowering influence of the campaign ~~forces~~<sup>forces</sup> and thus the futility in trying to do battle with them, I planned, with the resources I had, telephone and canvassing operations in such a way as to create the impression of the greatest possible force imaginable. I wanted to assure that retailers would be personally confronted with the brunt of every facet of the campaign from every possible direction.

First I identified store executives and as many of their relatives, close friends, associates and store personnel as possible. Then I marked on a map where each of these persons lived. A list was then made of the streets these people lived on as well as several of the streets which surrounded their homes. Then I went to the street section of the city directories, xeroxed the names, addresses and phone numbers of everyone living on each of these streets. Telephone and canvassing assignments were then made from these lists.

In order to create an immediate psychological impact, the strategy was to first concentrate our canvassing and telephoning operations on those areas where the persons we identified lived. Each of those persons homes would have been canvassed and telephoned as would the homes of 500-1000 of their neighbors. The fact that many of the persons in these targeted areas were closely associated with the store executives did not bother me. In fact that was an important part of the whole strategy.

I expected retailers would receive a constant barrage of feedback from concerned friends from all over the metropolitan area of the bad publicity their stores were receiving. The idea here was not to build actual boycott pressures from consumers that would be felt at the cash register, but to create the impression in retailers minds that they were up against a force so awesome and overpowering that it would be useless to fight it. Any doubts regarding the power labor had and its willingness to use that power would be answered. The only sensible thing left to do would be to give-in to labor's demands.

In order to create immediate boycott pressure which would be felt by retailers at the cash register, I targeted areas heavily populated by union members. Each of the largest retailers had at least one store, located in one of these targeted areas, which relied heavily on the business done by union members and their families. If union members in these areas ever blacklisted a store, that store probably would be forced to close down. The telephone assignments for these areas could have been set up using either the street or the telephone section of the directory depending upon whether we wanted to cover an entire exchange area or just a section of it. In the Birmingham area, it happened that geographical areas could be distinguished by telephone exchanges numbers. Thus by calling all the numbers under one telephone exchange, an entire geographical area could be covered. If we decided to cover only a section of that particular geographical area instead of all of it, we could have mapped that section out and then reverted back to making up our telephone and canvassing assignments from the street section of the directory. Persons in these targeted areas would be informed that a particular store had ignored labor's urgent and legitimate request that they stop ordering <sup>scab</sup> Farah Slacks until Farah workers were treated fairly and decently and the strike situation at Farah plants had been settled. That store would soon become a topic of controversy and union members and their sympathizers would have made their concerns felt at the cash register.

If my telephone campaign has to depend on volunteers making calls from their

homes, I prepare many telephone campaign packets to assign to volunteers. Each packet would consist of names and phone numbers of persons in an area being targeted, the telephone message, a set of instructions for telephoners, a talley sheet and an issue-fact sheet. My initial phone contact in the Farah campaign, because of my limited financial resources, the tempo of the campaign, and my immediate strategy, would have been nothing more than a simple message brief and to the point. The only notation made by a persons name would have been a checkoff signifying that they had been called and the boycott message had been relayed to them.

Other types of telephone campaigns however can be much more complex especially if conducted from a centralized telephone bank with the objective to categorize and record different responses regarding an issue. They can become even more complex and highly systematized if the call is to serve a number of purposes including the recruitment of volunteers to take an active part in a campaign.

The following pages describe in detail different types of telephone systems and the tremendous potential they have in any organizational effort: *(See Organizing: A Guide For Social Activists by Ray Rogers, pgs 9-19; see other unpublished materials on telephone systems by contacting Ray Rogers)*

MURRAY H. FINLEY  
General President  
JACOB SHEINKMAN  
General Sec'y-Treas.

# AMALGAMATED CLOTHING WORKERS

OF AMERICA - AFL-CIO, CLC



15 UNION SQUARE • NEW YORK, N.Y. 10003 • TELEPHONE: 255-7800

VICE-PRESIDENTS

OMA BARTON  
SOL BRÄNDZEL  
DAVID CHANEY  
ABRAHAM CHATMAN  
ANTHONY CORTIGEN  
CHARLES S. ENGLISH  
CHARLES J. GARRAHAN  
SANDER GENIS  
WILLIAM C. HALL  
LOUIS HOLLANDER  
VINCENT LACAPRIA  
HARRY LAUTMAN  
LEONARD LEVY  
LEONARD LEWIS  
MANUEL MENÉNDEZ  
SAM NOCELLA  
DIANA NUNES  
HOWARD D. SAMUEL  
LOUIS SIMON  
PETER J. SWOBODA  
VAL WERTHEIMER

Rabbi Brickner---People to contact on Farmworker Project

Labor--

AFL-CIO, Allyn Kistler, Director of Organization  
Jacob Clayman, Director, Industrial Union Dept.  
UAW--Martin Gerber, Director, ~~District~~ Region 9  
AFSME--Victor Gottbaum, NYC  
Jack Conway, Ex. Dir., Washington, D.C.  
UMW--Arnold Miller

Church--

Broadway U.C.C.--Larry Durgin  
National Council of Churches--Chris Hartmire  
Lou Walker

U.C.C.--John Moyer

U.P.--Dean Lewis

D.of C.--<sup>A</sup>Garnet Day

Episcopal--Paul Moore, Jim Morton

U.M.--Dudley Ward  
Randy Nugent

American Baptist--Elizabeth Miller

Southern Baptist--Foy Valentine

American Lutheran

Lutheran Church in America--Bob Marshall